

---

Instruction Manual

Digital Sixteen/Nine Channels Video Recorder

***EDR1640***

***EDR1620***

***EDR920***

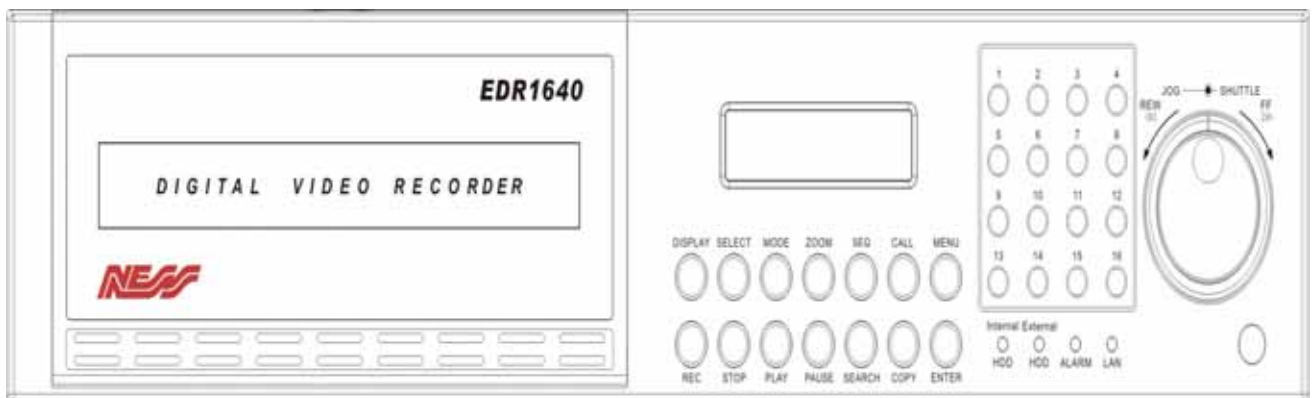

### **Federal Communication Commission Interference Statement**

This equipment has been tested and found to comply with the limits for a Class B digital device, pursuant to Part 15 of the FCC Rules. These limits are designed to provide reasonable protection against harmful interference in a residential installation. This equipment generates, uses and can radiate radio frequency energy and, if not installed and used in accordance with the instructions, may cause harmful interference to radio communications. However, there is no guarantee that interference will not occur in a particular installation. If this equipment does cause harmful interference to radio or television reception, which can be determined by turning the equipment off and on, the user is encouraged to try to correct the interference by one of the following measures :

- Reorient or relocate the receiving antenna.
- Increase the separation between the equipment and receiver.
- Connect the equipment into an outlet on a circuit different from that to which the receiver is connected.
- Consult the dealer or an experienced radio/TV technician for help. FCC Caution: Any changes or modifications not expressly approved by the party responsible for compliance could void the users's authority to operate this equipment. This device complies with Part 15 of the FCC Rules. Operation is subject to the following two conditions: (1) This device may not cause harmful interference, and (2) this device must accept any interference received, including interference that may cause undesired operation. This device and its antenna(s) must not be co-located or operating in conjunction with any other antenna or transmitter.

## CE Declaration

This equipment has been tested and found to comply with the limits for a **CE Class B** digital device,

The changes or modifications not expressly approved by the party responsible for compliance could void the user's authority to operate the equipment.

In a domestic environment this product may cause radio interference. In which case the user may be required to take adequate measures.



# Table of Contents

<b>1. PRODUCT OVERVIEW .....</b>	<b>1</b>
1.1 FEATURES .....	1
1.2 SPECIFICATIONS.....	2
1.3 FRONT PANEL KEYPADS .....	4
1.4 BACK PANEL CONNECTIONS .....	7
1.5 MONITOR DISPLAY .....	10
<b>2. INSTALLATION.....</b>	<b>13</b>
2.1 PACKING.....	13
2.2 SYSTEM FLOORPLAN .....	13
2.3 BASIC WIRING INSTRUCTIONS.....	14
2.4 HARD DISK DRIVE INSTALLATION .....	16
2.5 FINAL INSTALL PROCESS.....	16
<b>3. DVR MENU SETUP .....</b>	<b>17</b>
3.1 TIME/DATE SETUP MENU .....	18
3.2 CAMERA SETUP MENU.....	22
3.3 RECORD SETUP MENU .....	25
3.4 ALARM SETUP MENU .....	27
3.5 MOTION SETUP MENU .....	31
3.6 VLOSS SETUP MENU.....	35
3.7 NETWORK SETUP MENU .....	37
3.7.1 <i>CONFIG</i> .....	37
3.7.2 <i>ALARM NETWORK (Reserved)</i> .....	40
3.7.3 <i>EMAIL</i> .....	41
3.7.4 <i>PASSWORD</i> .....	43
3.7.5 <i>PPPoE</i> .....	45
3.7.6 <i>DDNS</i> .....	47
3.8 SCHEDULE SETUP MENU.....	49
3.9 DISK SETUP MENU.....	51
3.10 CONTROL SETUP MENU.....	53

3.11	WARNING SETUP MENU .....	55
3.11.1	FAN FAULT .....	55
3.11.2	HDD TEMP .....	57
3.11.3	NO HDD .....	59
3.11.4	HDD FULL .....	60
3.12	SYSTEM SETUP MENU .....	62
<b>4.</b>	<b>RECORDING OVERVIEW .....</b>	<b>66</b>
4.1	INSTANT (N) RECORDING SETUP .....	66
4.2	SCHEDULE RECORDING SETUP .....	67
4.3	EVENT RECORDING SETUP .....	68
<b>5.</b>	<b>PLAYBACK OVERVIEW .....</b>	<b>71</b>
5.1	BASIC PLAYBACK .....	71
5.2	SEARCH PLAYBACK .....	74
<b>6.</b>	<b>COPYING VIDEO .....</b>	<b>77</b>
6.1	VIEWING A COPIED FILE .....	79
<b>7.</b>	<b>CALL OVERVIEW .....</b>	<b>81</b>
<b>8.</b>	<b>SCREEN DISPLAY SETTING &amp; MODE .....</b>	<b>83</b>
8.1	MODE BUTTON .....	85
<b>9.</b>	<b>UPGRADE FIRMWARE .....</b>	<b>86</b>
<b>10.</b>	<b>NETWORKING OVERVIEW .....</b>	<b>87</b>
10.1	INTRODUCTION TO TCP/IP .....	87
10.2	SUBNET MASKS .....	87
10.3	GATEWAY ADDRESS .....	88
10.4	VIRTUAL PORTS .....	88
10.5	PRE-INSTALLATION .....	88
10.6	WHAT TYPE OF NETWORK CONNECTION DO YOU HAVE ? .....	90
10.7	SIMPLE ONE TO ONE CONNECTION .....	91
10.8	DIRECT HIGH SPEED MODEM CONNECTION .....	97

10.9	ROUTER OR LAN CONNECTION.....	99
<b>11.</b>	<b>LINKSYS PORT FORWARDING .....</b>	<b>102</b>
<b>12.</b>	<b>D-LINK PORT FORWARDING.....</b>	<b>107</b>
<b>13.</b>	<b>DDNS.....</b>	<b>112</b>
13.1	CREATING A DDNS ACCOUNT.....	112
<b>14.</b>	<b>VIEWING THROUGH INTERNET EXPLORER.....</b>	<b>115</b>
14.1	SEARCH.....	121
14.1.1	<i>Search by Time.....</i>	<i>121</i>
14.1.2	<i>Search by EVENT.....</i>	<i>122</i>
14.2	PTZ CONTROL.....	123
14.3	REMOTE ARCHIVE.....	125
<b>15.</b>	<b>INTERFACE SPECIFICATIONS.....</b>	<b>129</b>
15.1	TRANSMISSION SETTING.....	130
<b>APPENDIX A: REMOTE CONTROL.....</b>		<b>131</b>
<b>APPENDIX B: ALARM BOARD CONFIGURATION.....</b>		<b>132</b>
<b>APPENDIX C: RJ45 (RS485) PIN ASSIGNMENT.....</b>		<b>133</b>
<b>APPENDIX D: TIME LAPSE MODE RECORDING TABLE .....</b>		<b>134</b>
<b>TROUBLESHOOTING.....</b>		<b>137</b>

## Safety Warning

**WARNING**

TO REDUCE RISK OF FIRE OR ELECTRIC SHOCK,  
DO NOT EXPOSE THIS APPLIANCE TO RAIN OR MOISTURE.

**CAUTION**

DO NOT REMOVE COVER. NO USER SERVICEABLE PARTS  
INSIDE.

**Note:**

This equipment has been tested and found to comply with the limits for a Class A digital device,  
The changes or modifications not expressly approved by the party responsible for compliance could void the user's authority to operate the equipment.

**Note:**

This is a class A product. In a domestic environment this product may cause radio interference  
In which case the user may be required to take adequate measures.

**Notice:**

The information in this manual was current when published.  
The manufacturer reserves the right to revise and improve its products.  
All specifications are therefore subject to change without notice.

## Safety Precautions

- Refer all work related to the installation of this product to qualified service personnel or system installers.
- Do not block the ventilation opening or slots on the cover.
- Do not drop metallic parts through slots. This could permanently damage the appliance? Turn the power off immediately and contact qualified service personnel for service.
- Do not attempt to disassemble the appliance. To prevent electric shock, do not remove screws or covers. There are no user-serviceable parts inside. Contact qualified service personnel for maintenance. Handle the appliance with care. Do not strike or shake, as this may damage the appliance.
- Do not expose the appliance to water or moisture, nor try to operate it in wet areas. Do take immediate action if the appliance becomes wet. Turn the power off and refer servicing to qualified service personnel. Moisture may damage the appliance and also cause electric shock.
- Do not use strong or abrasive detergents when cleaning the appliance body. Use a dry cloth to clean the appliance when it is dirty. When the dirt is hard to remove, use a mild detergent and wipe gently.
- Do not overload outlets and extension cords as this may result in a risk of fire or electric shock.
- Do not operate the appliance beyond its specified temperature, humidity or power source ratings. Do not use the appliance in an extreme environment where high temperature or high humidity exists. Use the appliance at temperature within indoor type DVR for 0°C ~ +40°C and a humidity below 90%. The input power source for this appliance is AC100~240V.



## Safety Precautions

**Read Instruction** — All the safety and operating instructions should be read before the unit is operated.

**Retain Instructions** — The safety and operating instructions should be retained for future reference.

**Heed Warnings**— All warnings on the unit and in the operating instructions should be adhered to.

**Follow Instructions**— All operating and use instructions should be followed.

**Cleaning**— Unplug the unit from the outlet before cleaning. Do not use liquid cleaners or aerosol cleaners. Use a damp cloth for cleaning.

**Attachments**—Do not use attachment not recommended by the product manufacturer as they may cause hazards.

**Water and Moisture**—Do not use this unit near water—for example, near a bath tub, wash bowl, kitchen sink, or laundry tub, in a wet basement, near a swimming pool, in an unprotected outdoor installation, or any area which is classified as a wet location.

**Servicing**—Do not attempt to service this unit by yourself as opening or removing covers may expose you to dangerous voltage or other hazards. Refer all servicing to qualified service personnel.

**Power Cord Protection**—Power supply cords should be routed so that they are not likely to be walked on or pinched by items placed upon or against them, paying particular attention to cords and plugs, convenience receptacles, and the point where they exit from the appliance.

**Object and Liquid Entry**—Never push objects of any kind into this unit through openings as they may touch dangerous voltage points or short-out parts that could result in a fire or electric shock. Never spill liquid of any kind on the unit.

## **1. Product Overview**

This is the industry's first full-featured digital video recorder designed specifically for use within the security industry. The DVR incorporates all the benefits of digital video recording, is simple to install, and operates just like a VCR. Highly efficient compression technology and superior resolution of recorded images make the Digital Video Recorder stand out from the competition as the best choice for security surveillance.

### ***1.1 Features***

- ➔ Multiplex Operation (Recording, Playback, Archiving, Remote viewing)
- ➔ Built-in MPEG4 Codec with Configurable Quality
- ➔ 16CH. DVR: Variable Recording Speeds Up to 480/400(CIF) Pictures per second for NTSC/PAL
- ➔ Audio Recording Capabilities
- ➔ Motion Detection Capabilities
- ➔ Two 3.5" Hot-Swap Hard Disks
- ➔ SCSI Interface for External Expanded Storage
- ➔ Ethernet Interface for Remote Network Viewing and Controlling
- ➔ RS232/RS485 for Remote Control
- ➔ Shuttle/Jog Dial for Picture-by-Picture or Fast/Slow Viewing
- ➔ Easy-to-use User Friendly Control via Front panel keypad, Shuttle/Jog, Mouse and Control Keyboard (optional)
- ➔ On-Screen Menus Operations with Multi-Language Support
- ➔ Real-Time Live Display for all Cameras
- ➔ USB 2.0 Interface for Archiving
- ➔ Support external DVD+RW for Archiving (optional)
- ➔ Water Mark Capabilities

## 1.2 Specifications

<b>Video Format</b>	NTSC/EIA or PAL/CCIR
<b>Video Input</b>	16 camera inputs (BNC), 1Vp-p/75ohm
<b>Video Output</b>	1 BNC video out (1Vp-p/75ohm) and S-Video out for Main Monitor 1 BNC video out (1Vp-p/75ohm) for CALL Monitor 16 video out (1Vp-p/75ohm) for Looping
<b>Video Compression</b>	MPEG4
<b>Recording Resolution</b>	720x480 (NTSC:120IPS) / 720x576 (PAL:100IPS) 720x240 (NTSC:240IPS) / 720x288 (PAL:200IPS) 360x240 (NTSC:480IPS) or 360x288 (PAL:400IPS)
<b>Video Display</b>	Full, 4,7, 9,10,13,16,PictureInPicture (Live only) and 2x2 Zoom for Live and Playback
<b>Video Pause</b>	Yes
<b>Alarm Inputs</b>	16/9 Alarm Inputs
<b>Alarm Outputs</b>	1 Alarm Output
<b>Hard Disk Storage</b>	Two Hot-Swappable 3.5" IDE Hard Disk (optional)
<b>Recording Rate</b>	Please refer to <b>**Note**</b> at the following page
<b>Recording Mode</b>	Continue, Time-lapse, Schedule or Event recording (Motion, Video Loss, Alarm)
<b>Playback Rate (only 1 CODEC records)</b>	D1: Up to 30/25 Pictures per second for NTSC/PAL Half D1: Up to 60/50 Pictures per second for NTSC/PAL CIF: Up to 120/100 for NTSC/PAL
<b>Playback Search</b>	By Date/Time or Event (Alarm,Video Loss, Motion)
<b>Motion Detection</b>	Yes, with configurable detection area & sensitivity
<b>Video Loss Detection</b>	Yes
<b>Event Log</b>	Yes
<b>User Interface</b>	OSD Menu Driven
<b>Setup</b>	On screen display setup
<b>User Input Device</b>	Front panel keypad, Shuttle/Jog, Mouse, Control Keyboard, Remote Control(Optional)
<b>Timer</b>	Built-in real time clock and Auto Time Synchronization with global NTP server through Internet
<b>Watch Dog Timer</b>	Yes
<b>Title</b>	12-characters title for each camera
<b>Ethernet</b>	RJ45 connectors for network communication
<b>Archive</b>	USB for archiving
<b>RS-232</b>	9-pin female connector for local communication
<b>RS-485</b>	for Keyboard connection
<b>Audio</b>	2 mono inputs, 2 mono (SPEAKER) outputs
<b>Power Rate</b>	DC 12V/DC 24V

<b>Dimension</b>	Full size: 430mm (L) x 300mm (W) x 88mm (H)
<b>Weight</b>	4.85 KG
<b>Operating Temperature</b>	0°C ~ +50°C
<b>Remote Controller</b>	IR Remote Controller

**\*\* NOTE\*\***

<b>Recording Rate</b>	<b>NTSC</b>	<b>PAL</b>
1640 model	<b>D1</b> 720x480 : 120 IPS <b>Half D1</b> 720x240 : 240 IPS <b>CIF</b> 360x240 : 480 IPS	<b>D1</b> 720x576 : 100 IPS <b>Half D1</b> 720x288 : 200 IPS <b>CIF</b> 360x288 : 400 IPS
1620 model	<b>D1</b> 360x240 : 60 IPS <b>Half D1</b> 360x120 : 120 IPS <b>CIF</b> 180x120 : 240 IPS	<b>D1</b> 360x288 : 50 IPS <b>Half D1</b> 360x144 : 100 IPS <b>CIF</b> 180x144 : 200 IPS
920 model	<b>D1</b> 360x240 : 60 IPS <b>Half D1</b> 360x120 : 120 IPS <b>CIF</b> 180x120 : 240 IPS	<b>D1</b> 360x288 : 50 IPS <b>Half D1</b> 360x144 : 100 IPS <b>CIF</b> 180x144 : 200 IPS

### 1.3 Front Panel Keypads

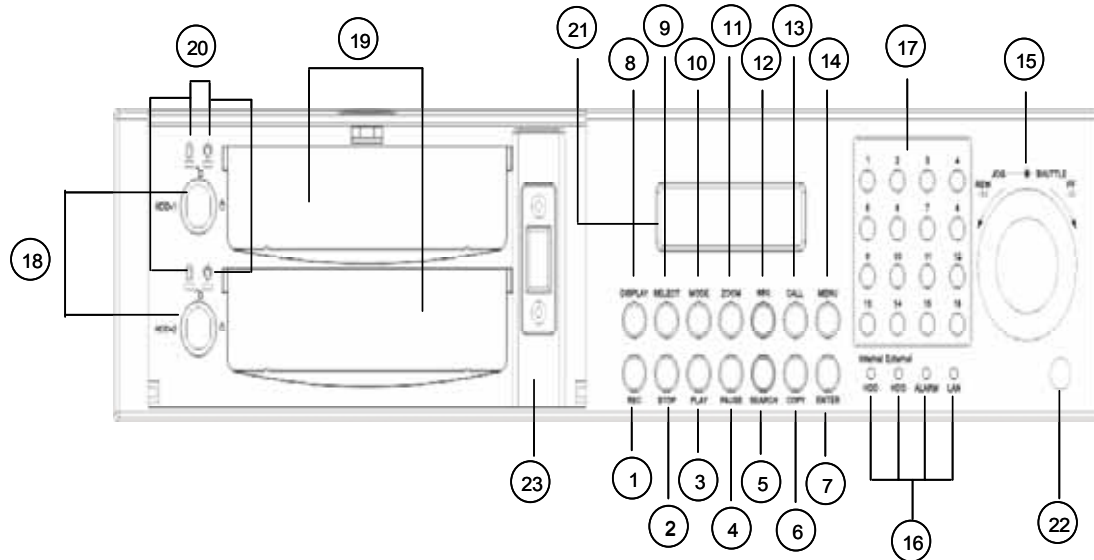

Keys:

- ① **REC:** Press this key to start instant recording.
- ② **STOP:** Press this key to stop recording and playing back.
- ③ **PLAY:** Play Back.
- ④ **PAUSE:** Press this key to pause the playback picture.
- ⑤ **SEARCH:** Press this key to enter the **SEARCH MENU**.
- ⑥ **COPY:** Press this key to start to copy a still picture under **PAUSE** mode or copy a video stream into USB.
- ⑦ **ENTER:** Press this key to enter items, or jump to next subentry in the menu setting.

- ⑧ **DISPLAY:** Press this key to switch display of channels, display color of channels (Black, Red, Yellow, Pink, Green and White are available as choices) and/or status bar.

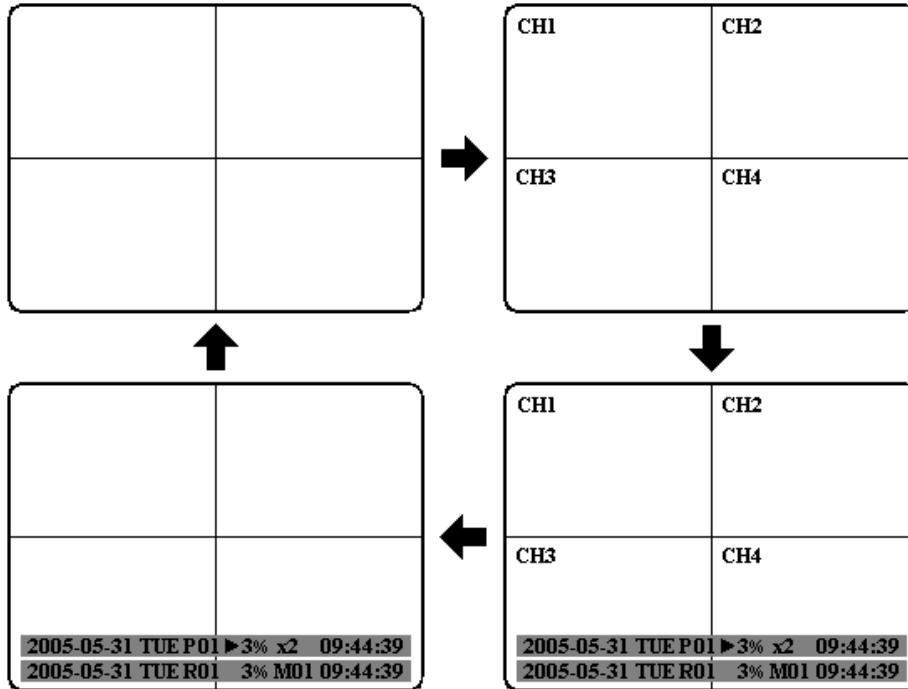

- ⑨ **SELECT:** Press this key to select, to assign a camera to a display, to adjust screen display, and so on.

- ⑩ **MODE:** Switch PIP, 4, 7, 9, 10, 13 and 16 displays in **Live** and **Playback** modes.

- ⑪ **ZOOM:** Press this key while viewing the full screen image to display a magnified resolution on the monitor. You must be in "Full" screen mode first before zooming. While zooming, all other function keys will be disabled until you press "ZOOM" again to exit "ZOOM" mode.

- ⑫ **SEQ:** Press this key to enter the auto sequential switching mode.

⑬ **CALL:** Press this key to enter and set up **CALL MENU**.

⑭ **Menu:** Press this key to enter or quit **MAIN SETUP MENU**.

⑮ **Shuttle and Jog Dial**

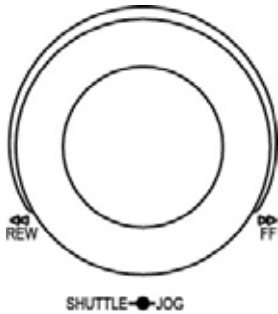

**Shuttle:**

In the **Playback** mode, turn the **Shuttle** dial to fast forward/rewind the video.

In the **Pause** mode, turn the **Shuttle** dial to slow forward/rewind the video.

In the **Search** mode, turn the **Shuttle** to change pages.

**Jog Dial:**

In the **Pause** mode, turn the **Jog** dial to forward/rewind the video.

In the **Menu** mode, turn the **Jog** dial to change settings and values in subentries.

⑯ **System LEDs:** LEDs for system active **HDD**, **ALARM** and **LAN** display.

⑰ **Channel Key (1~16):** Press Channel Key (**CH1~CH16**) to display video image in the full screen format, the corresponding picture will fill the whole screen of the monitor display.

⑱ **HDD LOCK:** Protect HDD without steal and turn on HDD power.

⑲ **Hard Disk Tray:** Hard Disk holder for HDD.

⑳ **HDD LEDs:** LEDs for HDD active power (**GREEN**) and data reading /writing (**YELLOW**).

㉑ **LCD Panel:** To display Date and Time, and other system information.

㉒ **Remote Control:** IR remote control receiver.

㉓ **USB Slot:** USB port allows you to archive files into your storages.

## 1.4 Back Panel Connections

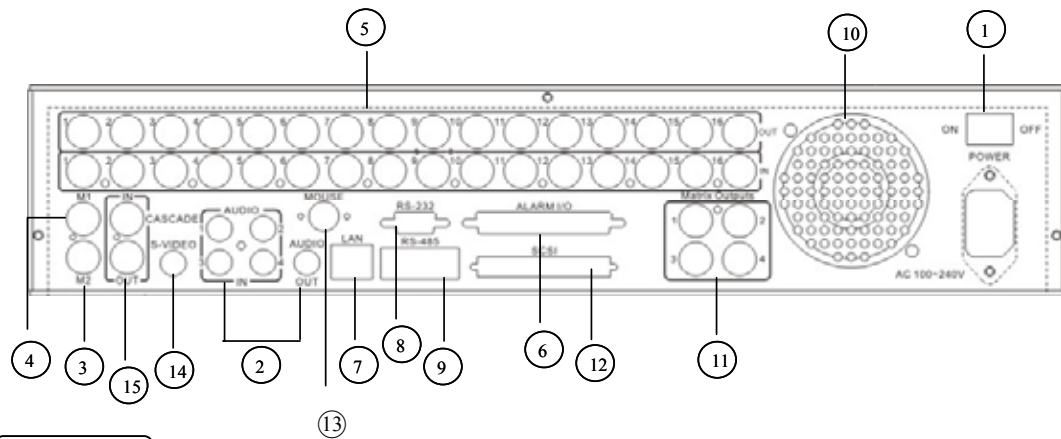

### POWER

- ① **Main Power plug:** Connect power jack (AC 100V).
- ② **Audio IN:** Audio inputs 1~4 for recording, and it can be enabled by setting to “YES” or “NO” in the **RECORD SETUP MENU**.  
**Audio OUT:** Connect an audio output to a monitor or other device.

### MONITOR

- ③ **MAIN MONITOR:** This connector is used for the main monitor display, a number of different display modes may be selected for viewing.
- ④ **CALL MONITOR:** This connector is used for the call monitor. This monitor can only display a full screen.



## VIDEO IN

### ⑤ For 16 CH DVR Series:

**VIDEO OUT (1~16):** BNC connectors for video looping out 1~16.

**VIDEO IN (1~16):** BNC connectors for video input 1~16.

### For 9 CH DVR Series:

**VIDEO OUT (1~9):** BNC connectors for video looping out 1~9.

**VIDEO IN (1~9):** BNC connectors for video input 1~9.

## ALARM INPUT/OUTPUT

### ⑥ **ALM-INPUT:** Normal open or normal close type alarm signal inputs.

The Alarm Input can be selected as normal open (**N.O.**) or normal close (**N.C.**) input in the **ALARM SETUP MENU**. When an alarm occurs, alarm recording will automatically start.

**ALM-OUTPUT:** A built-in relay offers 3 nodes which are **ALM-COM** (common), **ALM-NO** (normal open) and **ALM-NC** (normal close) for external use. **Note:** Please check **APPENDIX C** to see other available alarm input/output functions.

## LAN

### ⑦ **LAN Connector:** The RJ-45 LAN connector.

## RS232

### ⑧ **RS232 connector:** Connect D-Sub 9 pins connector to RS232 ports for remote control.

## RS485

### ⑨ **RS485 connector:** RJ 45 Connector to Cascade multi Digital Video Recorder.

## Wireless (Reserved)

### ⑩ **FAN:** Cooling FAN.

## Matrix

### ⑪ **Matrix outputs 1~4:** BNC connectors for Matrix outputs 1~4.

### SCSI

- ⑫ **SCSI Connector:** For connecting the optional extension unit.

### Mouse

- ⑬ **Mouse:** For connecting the mouse.

### S-Video

- ⑭ **S-Video:** providing S-Video connector.

### Cascade

- ⑮ **Cascade** is designed for connecting a number of DVRs to one monitor.

You will be allowed to view and to control as many DVRs as you prefer from the same monitor simply by switching the screen using EKB500 keyboard controller.

Connect from **Cascade out** of the DVR to **Cascade In** of another with BNC connectors. Repeat the same step for all of your DVRs until you connect the last Cascade Out to Monitor's **Video In**.

## 1.5 Monitor Display

The status information of the cameras or machine will show up, and be located at different places on the screen.

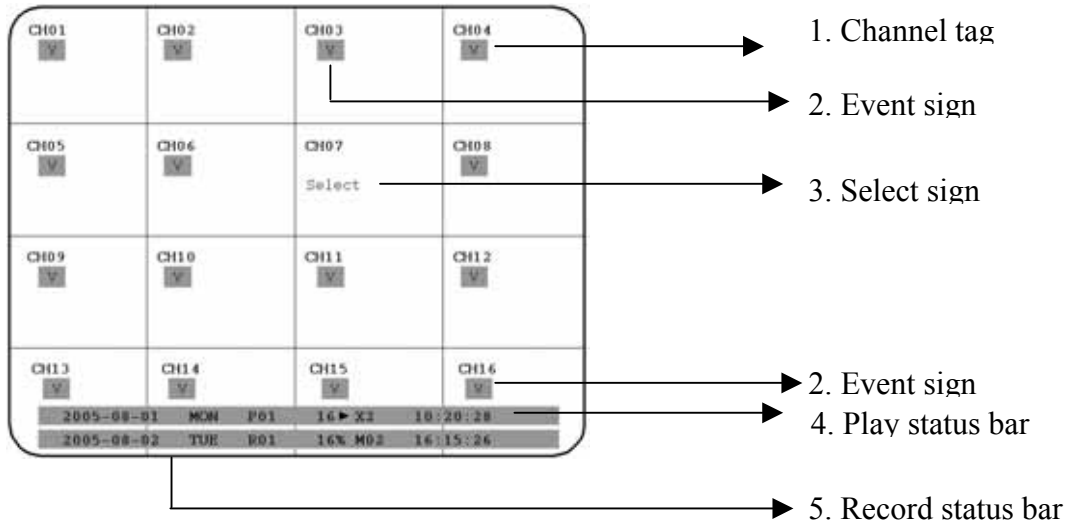

① **Channel tag:** A channel tag indicates the channel name of the screen.

② **Event sign:** Event signals which are small icons with a capital letter and red background show the events on each screen. There are totally 6 different signals which are:

**A** Alarm event. The alarm place where the camera locates. In order to show the camera video to a corresponding alarm, setting a **FOCUS CAMERA** in **ALARM SETUP MENU** is necessary.

**M** Motion event. Motion event only shows up when the camera's **MOTION** is enabled in **MOTION SETUP MENU**, and the camera detects a motion.

**V** Video loss event. Video loss event only shows when the camera's **VLOSS** is enabled in **VLOSS SETUP MENU**, and the camera signal is lost.

**S** Sequence sign. Sequence sign shows up when the display is in the sequence mode. The sequence display is located on display with a “\*” sign in the last display of the screen. The **S** sign will replace “\*” sign in the display when sequence occurs.

**Note:** Sequence mode is unavailable only in 16-displays mode.

**T** Temperature indication. When HDD's temperature is overheated. Overheat temperature is determined in **HDD TEMPERATURE** of **WARNING SETUP MENU**.

**F** Fan fail indication. When the fan fails to work normally.

③ **Select sign:** You can assign a camera to a display by pressing **SELECT** key in live mode. Dial **Jog** to move the select sign to the display you would like to change camera, and then press channel key from the Channel Panel to relocate the camera.

④ **Play status bar:** The play status bar appears in play back mode if you enable a status bar on the screen (Please see **DISPLAY**, 8<sup>th</sup> item of **Front Panel Keypads**). Three parts that are **play date**, **play time** and **play status** are shown in the play status bar.

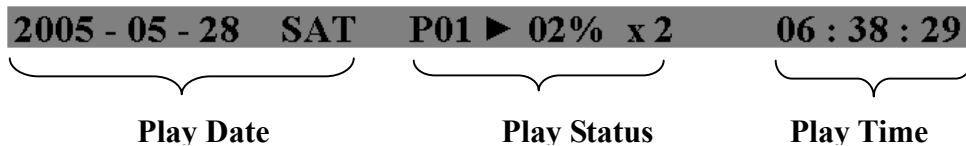

1. **Play date:** The play date in which the video is recorded.
2. **Play status:** It shows PAUSE, play speed and reverse play speed.
  - “PAUSE”, when the video play is paused.
  - “>” means normal play speed;
  - “<<” means normal reverse play speed;
  - “>> x N” means N time fast play speed;
  - “<< x N” means N time fast reverse play speed.

3. **Play time:** The play time at which the video is recorded. The time format depends on the time format setting in the **TIME/DATE SETUP MENU**.

⑤ **Record status bar:** The record status bar appears when you enable a status bar on the screen (Please see 8<sup>th</sup> item of **DISPLAY**). Three parts which are current date, record status (% of space used for recording) and current time.

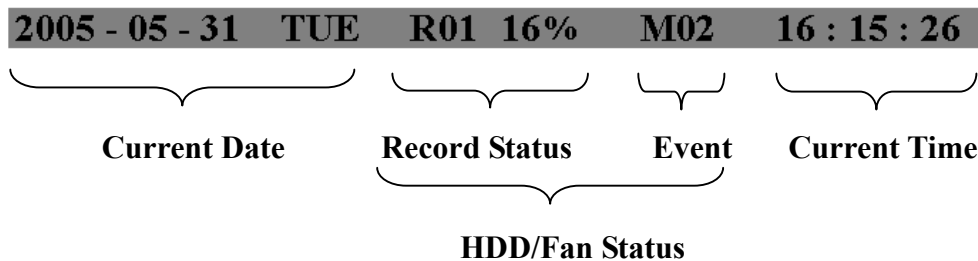

1. **Current date:** The current date which is set in the **TIME/DATE SETUP MENU**.
2. **Record status:** It shows REC and recording hard disk number.  
    “**REC**”, it shows when machine is recording.  
    “**R01**”, the recording hard disk number. There are two hard disks available in this model.
3. **Event:** The last happened event.
4. **Current time:** The current time which is set in the **TIME/DATE SETUP MENU**.
5. **HDD/Fan status:** “**No Disk**”, it shows when no disk is installed or detected.  
    “**No Fan**”, it shows when cooling fan stops working.

## 2. Installation

The installations described below should be done by qualified service personnel or system installers.

### 2.1 PACKING

Please check accessories in the packing before the installation.

**2.2 SYSTEM FLOORPLAN** Please refer to the following diagrams for the system connections.

**Note:** Monitor and Camera must be purchased separately.

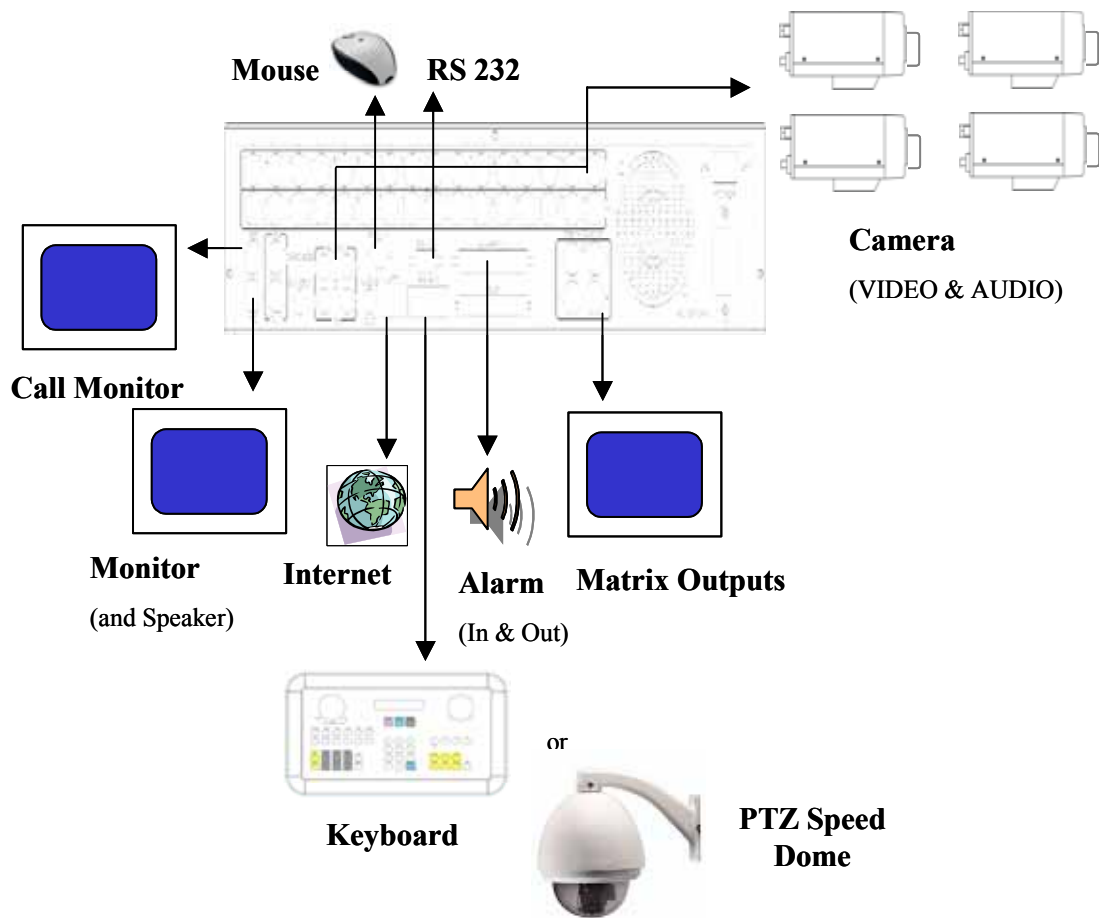

Diagram 2.1

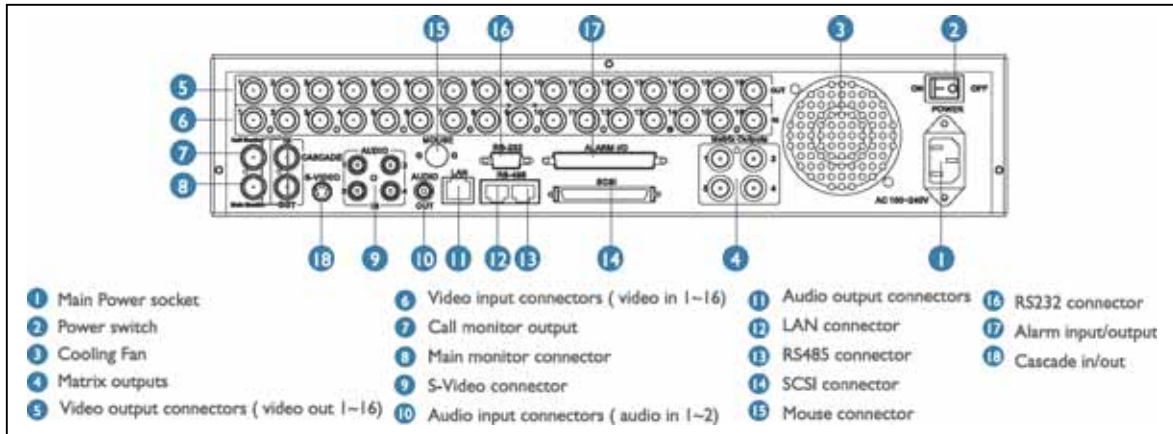

Diagram 2.2

## 2.3 Basic Wiring Instructions

Please refer to diagram 2.2 to assist you with this portion of the installation.

- **Power:** Connect the power source or adapter into the power socket.
- **Cameras:** Connect each cameras video output to the video input on the digital video recorder shown in diagram 2.1.
  - *Note: At least one camera must be connected before the system is running for the auto detection of video standard to take effect.*
- **Audio Input:** The camera audio output or Microphone is connected to the audio input terminal at the rear panel.
- **Audio Output:** Connect the speaker or other audio listening devices to the audio output terminal on the back of the digital video recorder.
- **Ethernet:** The digital video recorder may be viewed from a PC via the LAN connector using a RJ45 Ethernet cable.
- **RS232:** The digital video recorder can be controlled from a PC via RS232.
- **RS485:** The digital video recorder can be controlled from an EKB500 keyboard via RS485.

- *Note: This can be done using a serial cable.*
- **Main Monitor:** Connect the main monitor output connector to a main monitor. The main monitor displays selected live or recorded cameras in any available format.
- *Note: The main monitor must be connected in order to make configuration changes, enter the main menu, or do a playback at the machine.*
- **Call Monitors:** Connect the call monitor output connectors to a call monitor. The call monitor display selected live cameras in full screen format.
- *Note: The call monitor will only display one full screen camera at a time.*
- **Cascade:** **Cascade** is designed for connecting a number of DVRs to one monitor. You will be allowed to view and to control as many DVRs as you prefer from the same monitor simply by switching the screen using EKB500 keyboard controller. Connect from **Cascade out** of the DVR to **Cascade In** of another with BNC connectors. Repeat the same step for all your DVRs until you connect the last Cascade Out to Monitor's **Video In**.



## ***2.4 Hard Disk Drive Installation***

The first step in installing the hard drive is to insert the hard drive sleeve into the machine. The hard disk drive default setting is initially set to master. The second step is to insert the key provided and turn the tray key to the lock position. If this process is ignored the hard disk drive will not be detected. Follow the previous steps for the second hard drive or second empty sleeve.

- ***Note: If the Hard Disk Drive is not locked in with the key, HDD LED will not be lighted up, since HDD cannot be detected and the DVR will not go into record mode. This is because the Hard Drive is not being recognized.***
- ***Note:*** After powering on the DVR, it will start to load system. It takes a while to complete loading system, during this time, please do not install or remove the hard disk, none action is recommended when the machine is loading system.

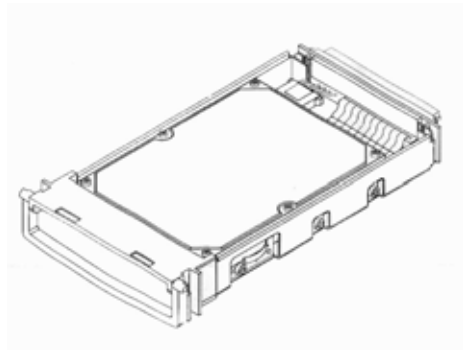

Diagram 2.2 shows 3.5" Hard Drive

## ***2.5 Final Install Process***

Once you have completed the basic wiring installation and the hard disk drive installation you are ready to turn on the DVR. Simply plug the power source you installed earlier. The POWER LED lights will light up if power is normal. The next step is to set up the menu options for the DVR.

### 3. DVR Menu Setup

Assuming you have completed the first two chapters of this manual. You are now ready to begin setting up the digital video recorder. The following chapter will walk you through the detailed DVR Menu step by step and how to set the DVR for your specific application. To begin this process, press the **MENU** key. Once inside the main menu you will find there are 12 setup option pages as follows.



MENU

Press the **MENU** key to enter the **MAIN MENU**.  
Press the **MENU** key to quit current setting, and go back to last setting.

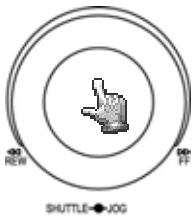

Dial the **Jog** clockwise or counterclockwise to change subentry values. Press the **ENTER** key to go next subentry in a menu setting, and press the **CALL** key to go last subentry in a menu setting. Or, simply use the mouse to go next or last subentry in a menu setting, and use tilt wheel of the mouse to move between every selection.

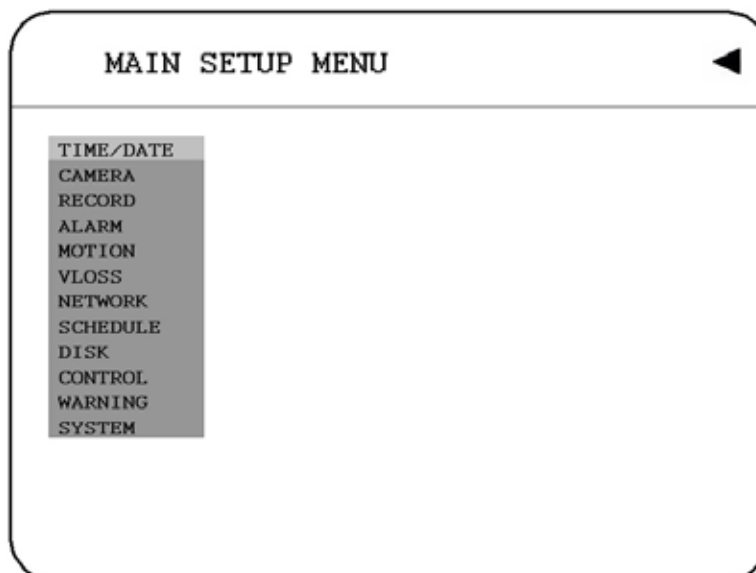

Diagram 3.1

### 3.1 Time/Date Setup Menu

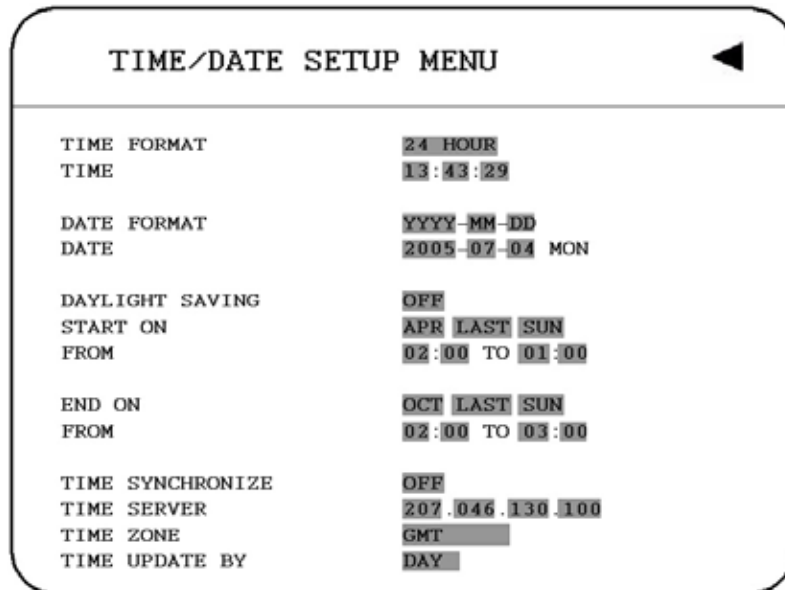

Diagram 3.2

Diagram 3.2 is a screen shot of the **TIME/DATE SETUP MENU**. This menu is used to set up the correct time and date for your region of the world. You are able to setup daylight savings as well as synch it with an internet based time server. In the **TIME/DATE SETUP MENU** the following fields are defined as follows:

- **TIME FORMAT:** This field represents the time format on the DVR. There are two time formats that are **12 HOUR** and **24 HOUR** to be selected.
- **TIME:** This field represents the current time on the DVR. To change this, simply use the Jog Dial on the DVR to make your selection.

The Time is represented as follows:

Hour: 00~23: Minute: 00~59: Second: 00~59 (1 ~ 12 if TIME FORMAT is 12 HOUR)

- **DATE FORMAT:** This field represents the date format on the DVR. To change this, simply use the Jog Dial on the DVR to make your selection. There are three date formats which are **YYYY-MM-DD**, **MM-DD-YYYY** and **DD-MM-YYYY** to be selected.

- **DATE:** This field represents the date on the DVR. To change this, simply use the Jog Dial on the DVR to make your selection. There are three date formats which are **YYYY-MM-DD**, **MM-DD-YYYY** and **DD-MM-YYYY** to be selected.

The date is represented as follows:

Year: 2000~2037 / Month: 01~12 / Date: 01~31 (Day of Week)

- **DAYLIGHT SAVING:** This field represents the daylight savings on the DVR. To change this, simply use the Jog Dial on the DVR to make your selection. Select “**ON**” or “**OFF**” to enable or disable daylight saving time function. In order to set a daylight saving time zone, you need to disable daylight saving first. Enable the daylight saving after finish setting the time zone.
- **START TIME:** To set the start time of daylight saving time.

**To set the start month of daylight saving time:** Dial the jog to set the start month.



**To set the start week of daylight saving time:** Dial the jog to set the start week.



**To set the start date of daylight saving time:** Dial the jog to set the start date.



**To set the start time of daylight saving time:** To set the start “**FROM**” time and “**TO**” time of daylight saving time.

- **END TIME:** To set the end time of daylight saving

**To set the end month of daylight saving time:** Dial the jog to set the end month.



**To set the end week of daylight saving time:** Dial the jog to set the end week.



**To set the end date of daylight saving time:** Dial the jog to set the end date.



**To set the end time of daylight saving time:** To set the end “FROM” time and “TO” time of daylight saving time.

- **TIME SYNCHRONIZE:** Select “ON” or “OFF” to enable or disable time synchronize which can let you have correct time automatically when network is connected. To change this, simply use the Jog Dial on the DVR to make your selection.

- **TIME SERVER:** You can set the time server address where you locate if you connect to network and enable time synchronize. For checking the IP address of NTP Server, please follow the steps:

1. Connect your PC to internet for searching the IP address of NTP Server.
2. Go to “START” -> “RUN” -> type “Command” and press “OK”

Under Dos Prompt, type “C:\Ping Pool.NTP.ORG to find out the IP address of NTP Server.

```
Command Prompt
C:\>ping pool.ntp.org
Pinging pool.ntp.org [209.126.142.251] with 32 bytes of data:
Reply from 209.126.142.251: bytes=32 time=203ms TTL=47
Reply from 209.126.142.251: bytes=32 time=203ms TTL=47
Reply from 209.126.142.251: bytes=32 time=203ms TTL=47
Reply from 209.126.142.251: bytes=32 time=203ms TTL=47
Ping statistics for 209.126.142.251:
    Packets: Sent = 4, Received = 4, Lost = 0 (0% loss),
    Approximate round trip times in milli-seconds:
        Minimum = 203ms, Maximum = 203ms, Average = 203ms
C:\>_
```

Diagram 3.3

- **TIME ZONE:** You can set the time zone where you locate if you connect to network and enable time synchronize.

Atlantic Daylight Time subtract 3 hours from GMT  
Atlantic Standard Time subtract 4 hours from GMT  
Eastern Daylight Time subtract 4 hours from GMT  
Eastern Standard Time subtract 5 hours from GMT  
Central Daylight Time subtract 5 hours from GMT  
Central Standard Time subtract 6 hours from GMT  
Mountain Daylight Time subtract 6 hours from GMT  
Mountain Standard Time subtract 7 hours from GMT  
Pacific Daylight Time subtract 7 hours from GMT  
Pacific Standard Time subtract 8 hours from GMT  
Alaska Daylight Time subtract 8 hours from GMT  
Alaska Standard Time subtract 9 hours from GMT  
Hawaii-Aleutian Daylight Time subtract 9 hours from GMT  
Hawaii-Aleutian Standard Time subtract 10 hours from GMT

- **TIME UPDATE BY:** Once you enable the **TIME SYNCHRONIZE**, you can select the synchronization frequency by:

**DAY**      **WEEK**      **MONTH**

### 3.2 Camera Setup Menu

CAMERA SETUP MENU			
CAMERA 1	TITLE	CH01	
CAMERA 2	PTZ ID	011	
CAMERA 3	INSTALL/COVERT	ON /OFF	
CAMERA 4	SEQ(MAIN/CALL)	03/03 SECS	
CAMERA 5	REC QUALITY	HIGH	
CAMERA 6			
CAMERA 7	REC SPEED ON	TIME ZONE	
CAMERA 8	TP NORMAL	EVENT	SET
CAMERA 9	1 1 IPS	30 IPS	OFF
CAMERA 10	2 1 IPS	30 IPS	OFF
CAMERA 11	3 1 IPS	30 IPS	OFF
CAMERA 12	4 1 IPS	30 IPS	OFF
CAMERA 13	5 1 IPS	30 IPS	OFF
CAMERA 14	6 1 IPS	30 IPS	OFF
CAMERA 15	7 1 IPS	30 IPS	OFF
CAMERA 16	8 1 IPS	30 IPS	OFF
SUMMARY	N 1 IPS	30 IPS	OFF

Diagram 3.4

Diagram 3.4 is a screen shot of the **CAMERA SETUP MENU**. This menu will walk you through setting up the Camera Recording Speeds, Camera titles, PTZ ID, covert modes, and recording quality. In the **CAMERA SETUP MENU** the following fields are defined as:

- **TITLE:** The title setting allows you to assign a title to each camera input. Titling with 12 characters is supported in each channel. To change this, simply use the Jog Dial on the DVR to make your selection. The available alphanumeric characters are:  
 0,1,2,3,4,5,6,7,8,9,  
 A,B,C,D,E,F,G,H,I,J,K,L,M,N,O,P,Q,R,S,T,U,V,W,X,Y,Z,  
 ( ) . , + - / and an empty space.
- **PTZ ID:** Select PTZ ID/Address from 001~255 or OFF. The default value is 10+N where N is camera's number. This ID must be the same as the ID used in PTZ Dip Switch. To change this, simply use the Jog Dial on the DVR to make your selection.
- **INSTALL/COVERT:** For installation of camera; select "ON" to enable a camera, and "OFF" to disable it. Please make sure to stop recording before making change of **INSTALL**. To take full advantage of the record resource,

switch the Uninstalled Camera Ports to OFF in this section. For **COVERT**, select “ON” to cover a camera, and disable the screen in live mode to show up. However, the image is recorded, and can be played back by user who has playback right. The covert channels will not show up on the sequence mode. To change this, simply use the Jog Dial on the DVR to make your selection.

- **SEQ (MAIN/CALL):** Setup a retention period for sequences. To change this, simply use the Jog Dial on the DVR to make your selection.
- **REC QUALITY:** Select an image quality for recording. Normal record image quality and event record image quality can be set individually. There are six different qualities available. A higher image quality needs more HDD space. To change this, simply use the Jog Dial on the DVR to make your selection. The theory space needed per second lists below:

720x480		Video Source	
		Simple:	Complex:
Average size per image	LOWER:	8.04KB	12.33KB
	LOW:	8.42KB	13.7KB
	BASIC:	10.15KB	16.72KB
	STANDARD:	11.86KB	19.56KB
	HIGH:	14.72KB	24.63KB
	SUPERIOR:	18.60KB	30.05KB
720x240		Video Source	
		Simple:	Complex:
Average size per image	LOWER:	3.53KB	7.82KB
	LOW:	3.87KB	8.36KB
	BASIC:	4.21KB	8.9KB
	STANDARD:	4.92KB	9.54KB
	HIGH:	5.62KB	10.17KB
	SUPERIOR:	6.41KB	12.89KB
360x240		Video Source	
		Simple:	Complex:
Average size per image	LOWER:	1.76KB	4.56KB
	LOW:	1.87KB	4.87KB
	BASIC:	1.97KB	5.46KB
	STANDARD:	2.38KB	6.51KB
	HIGH:	2.67KB	7.08KB
	SUPERIOR:	3.63KB	9.02KB



**Note: Since the compression ratio of MPEG4 fully depends on the variation and complexity of the recorded video, the table above is for your reference only.**

➤ **REC SPEED ON TIME PERIOD:**

**TP:** Scheduled recording time 1~8 which can be set in the **SCHEDULE SETUP MENU**. ‘N’ in the column of ‘TP’ is the normal recording time.

**NORMAL:** Normal record speed (Images per second) up to 15 IPS. The default normal record speed is 1 IPS. The DVR will adjust to the maximum recording speed by calculating the total installed cameras that have enabled in the **CAMERA SETUP MENU**.

**EVENT:** Event record speed (Images per second) up to 30 IPS or ‘OFF’.

*Note: In order to validate a new record speed, you need to disable all record actions before setting up.*

**SET:** Set ‘ON’ when using schedule recording.

Set ‘OFF’ when not using schedule recording.

*Note: The status of SET can only be changed in the SCHEDULE SETUP MENU.*

➤ **SUMMARY :**

CAMERA	ITEM	TITLE
CAMERA 1		
CAMERA 2	1	CH01_____
CAMERA 3	2	CH02_____
CAMERA 4	3	CH03_____
CAMERA 5	4	CH04_____
CAMERA 6	5	CH05_____
CAMERA 7	6	CH06_____
CAMERA 8	7	CH07_____
CAMERA 9	8	CH08_____
CAMERA 10	9	CH09_____
CAMERA 11	10	CH10_____
CAMERA 12	11	CH11_____
CAMERA 13	12	CH12_____
CAMERA 14	13	CH13_____
CAMERA 15	14	CH14_____
CAMERA 16	15	CH15_____
SUMMARY	16	CH16_____

Diagram 3.5

Dial **Jog** to change items in the **SUMMARY** table.

All cameras' statuses are shown in the **SUMMARY** table. The table is for checking camera overall statuses only, not for setting.

*Note: The **SUMMARY** table also exists in **ALARM**, **MOTION** and **VLOSS SETUP MENU**. All of these **SUMMARY** tables are also for checking particular overall statuses, not for setting.*

- **Copy camera's setting from a camera to other cameras:** In order to copy the setting from a camera to other cameras, we provide a setting copy function. Press **MENU** when you finish setting up a camera, and then press **COPY**. A **COPIED** sign will show up on the top right corner of the screen, and it means the setting has been copied. Dial the **Jog** to the camera you would like to copy, and then press **SEARCH** to paste. The previous setting of the camera will be covered, and a **PASTED** sign will show up.

**NOTE: TITLE, PTZ ID, INSTALL/COVERT** cannot be copied. These 3 options need to be set independently.

### 3.3 Record Setup Menu

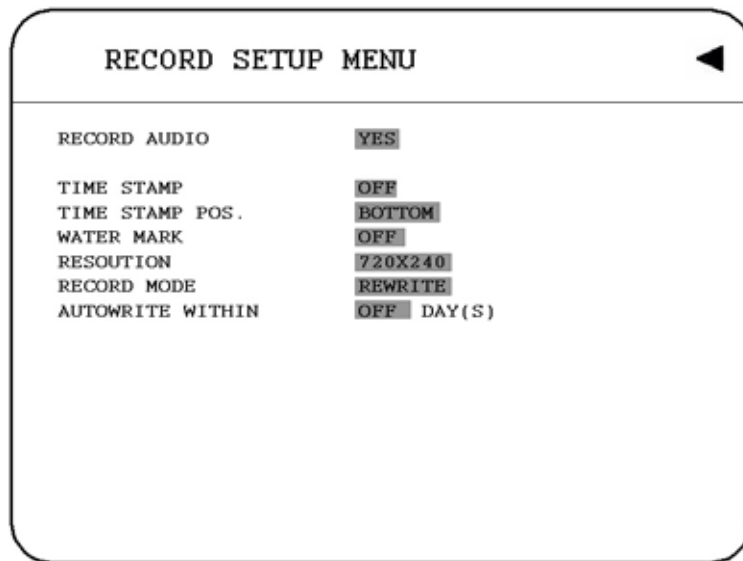

Diagram 3.6

Diagram 3.6 is a screen shot of the **RECORD SETUP MENU**. This menu is for setting up the options for recording. We define recording as something on which sound or visual images have been recorded. In the **RECORD SETUP MENU** the following fields are defined as follows:

➤ **RECORD AUDIO:**

**YES:** Audio will be recorded when machine is recording.

**NO:** Audio will not be recorded when machine is recording.

➤ **TIME STAMP:**

**ON:** The time stamp will show on the video and picture when recording.

**OFF:** The time stamp will not show on the video and picture when recording.

➤ **TIME STAMP POSITION:**

**BOTTOM:** The time stamp will show on the bottom.

**TOP:** The time stamp will show on the top.

➤ **WATER MARK:**

**ON:** Shows a water mark on the picture when copying image to USB flash memory.

**OFF:** This erases the water mark on the picture when copying image to USB flash memory.

➤ **RESOLUTION:** The resolutions for NTSC are 720x480, 720x240 and 360x240 to be selected. Its default value is 720x240. The resolutions for PAL are 720x288, 720x576 and 360x288 to be selected. Its default value is 720x288.

NOTE: Selecting a certain resolution will determine the amount of IPS the DVR will support.

NTSC

720x480 = 30 IPS (this IPS value is divided by the amount of cameras installed)

720x240 = 60 IPS (this IPS value is divided by the amount of cameras installed)

360x240 = 120 IPS (this IPS value is divided by the amount of cameras installed)

➤ **RECORD MODE:**

**REWRITE:** Continue recording. Disk will be overwritten if it is full.

**STOP:** Stop recording when disk is full.

➤ **AUTOWRITE WITHIN:** You can set DVR autowrite day, so that DVR will autowrite after the day number you set. If you do not wish to use this function, please set it OFF.

### 3.4 Alarm Setup Menu

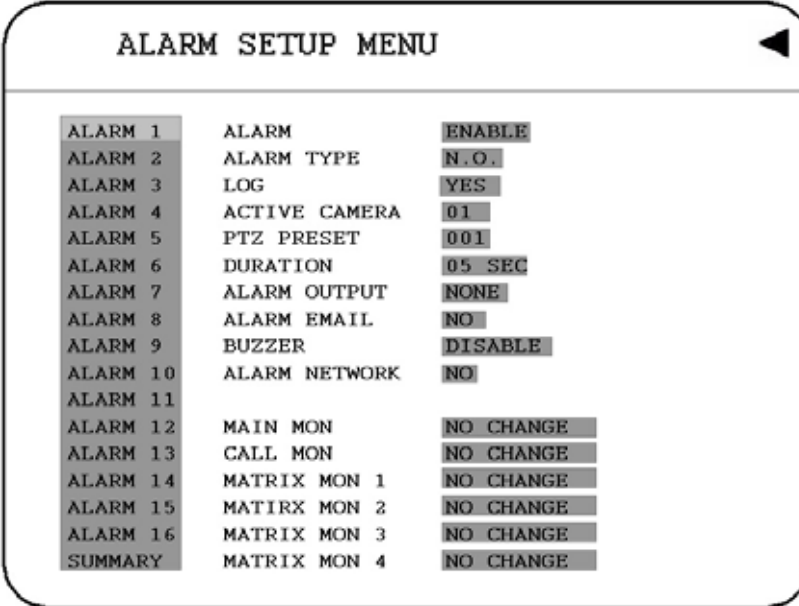

ALARM SETUP MENU		
ALARM 1	ALARM	ENABLE
ALARM 2	ALARM TYPE	N.O.
ALARM 3	LOG	YES
ALARM 4	ACTIVE CAMERA	01
ALARM 5	PTZ PRESET	001
ALARM 6	DURATION	05 SEC
ALARM 7	ALARM OUTPUT	NONE
ALARM 8	ALARM EMAIL	NO
ALARM 9	BUZZER	DISABLE
ALARM 10	ALARM NETWORK	NO
ALARM 11		
ALARM 12	MAIN MON	NO CHANGE
ALARM 13	CALL MON	NO CHANGE
ALARM 14	MATRIX MON 1	NO CHANGE
ALARM 15	MATRIRX MON 2	NO CHANGE
ALARM 16	MATRIX MON 3	NO CHANGE
SUMMARY	MATRIX MON 4	NO CHANGE

Diagram 3.7

Diagram 3.7 is a screen shot of the **ALARM SETUP MENU**. An alarm is defined as an electrical, electronic, or mechanical device that serves to warn of danger by means of a signal. In this case the signal triggers the recorder to start recording the alarmed event. This menu contains all the alarm operations and options needed to successfully complete an alarm recording. In the **ALARM SETUP MENU** the following fields are defined as:

- **ALARM:** This field is to turn alarm recording on or off. The Default from the factory is set to on. To change this, simply use the Jog Dial on the DVR to make your selection.

**ENABLE:** Enable alarm detection.

**DISABLE:** Disable alarm detection.

- **ALARM TYPE:** This field is to turn alarm recording on or off. The Default from the factory is set to on. To change this, simply use the Jog Dial on the DVR to make your selection.

**N. O.:** Normal Open alarm.

**N. C.:** Normal Close alarm.

**N.O. Trans.:** When the alarm is triggered, buzzer starts to function no matter how long the alarm duration is set until you set it back to N.O.

**N.C. Trans.:** When the alarm is triggered, buzzer starts to function no matter how long the alarm duration is set until you set it back to N.C.

➤ **LOG**

**YES:** Select **YES** if you wish to record Alarm Events in the Log.

**NO:** Select **NO** if you do not wish to record Alarm Events in the Log.

- **ACTIVE CAMERA:** This field is to activate camera you want to have the alarm enabled too. For example if you had an external motion detector on camera one you would set this option to camera one. The Default from the factory is set to on. To change this, simply use the Jog Dial on the DVR to make your selection.

**Active camera setting, from camera 01~16. You can set the camera which corresponds to the place where the alarm is located.**

*Note: The recording camera number in an event depends on the alarm number, and the active camera images will not be recorded. Example: You assign camera 3 as the active camera to alarm 1. When the alarm 1 is triggered, camera 3 will be displayed and camera 1 will be recorded.*

- **PTZ PRESET:** Select **PTZ PRESET** from “001” to “255”, so that when Alarm occurs, speed dome will turn to this preset position for event recording. This function improves surveillance quality of an alarm event. If you wish to disable this function, please simply select “OFF”.

- **DURATION:** The amount of time an alarm event will record - from 1 sec to 99 seconds. The default value is 5 seconds.

- **ALARM OUTPUT:** This will transmit a signal to another device. The setting of alarms are **NONE = not activated, 1 = output signal 1 transmitted, 2 = output signal 2 transmitted, 3 = output signal 3 transmitted and 4 = output signal 4 transmitted.**

- **ALARM EMAIL:** Select “YES” for sending an email when alarm occurs. The email address can be set in the **NETWORK SETUP MENU**.

- **BUZZER:** Audible alarm buzzer.

**ENABLE:** To enable an alarm buzzer.

**DISABLE:** To disable an alarm buzzer.

➤ **ALARM NETWORK:**

**YES:** Enable alarm network.

**NO:** Disable alarm network.

➤ **MAIN MON:** Display on a main monitor when an alarm occurs.

**NO CHANGE:** No change on the display in the main monitor when an alarm occurs.

**FULLSCREEN:** A full screen of the active camera will display when an alarm occurs.

➤ **CALL MON:** Display on a call monitor when an alarm occurs.

**NO CHANGE:** No change on the display in the main monitor when an alarm occurs.

**CAMERA 1~16 :** Display the active camera in full screen mode to the call monitor.

➤ **MATRIX MON 1:** Display on matrix monitor 1 when an alarm occurs.

**NO CHANGE:** Nothing changes on the display in the matrix monitor 1 when an alarm occurs.

**CAMERA 1~16:** Display an assigned camera in full screen mode to the matrix monitor 1.

➤ **MATRIX MON 2:** Display on matrix monitor 2 when an alarm occurs.

**NO CHANGE:** Nothing changes on the display in the matrix monitor 2 when an alarm occurs.

**CAMERA 1~16:** Display an assigned camera in full screen mode to the matrix monitor 2.

➤ **MATRIX MON 3:** Display on matrix monitor 3 when an alarm occurs.

**NO CHANGE:** Nothing changes on the display in the matrix monitor 3 when an alarm occurs.

**CAMERA 1~16:** Display an assigned camera in full screen mode to the matrix monitor 3.

➤ **MATRIX MON 4:** Display on matrix monitor 4 when an alarm occurs.

**NO CHANGE:** Nothing changes on the display in the matrix monitor 4 when an alarm occurs.

**CAMERA 1~16:** Display an assigned camera in full screen mode to the matrix monitor 4.

- **SUMMARY:** Dial **Jog** to change items in the **SUMMARY** table. All alarm's statuses are shown in **SUMMARY** tables. These tables are for checking alarm overall statuses, but not for setting.

*Note: Please check APPENDIX C to see other available alarm input / output functions.*

### 3.5 Motion Setup Menu

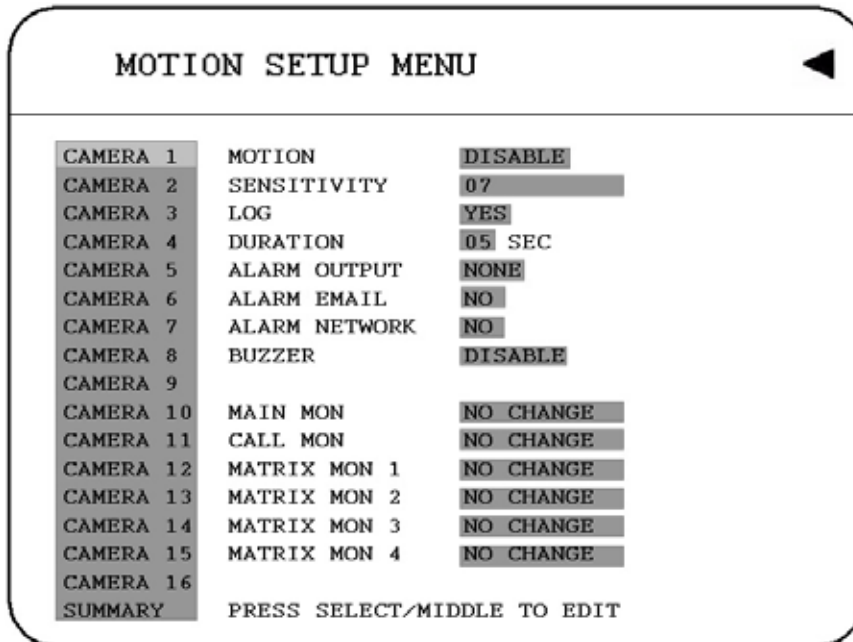

Diagram 3.8

Diagram 3.8 is a screen shot of the **MOTION SETUP MENU**. We define motion as a change of pixilation in the field of view, which is detected by the digital video recorder, and triggering the recorder to start recording. This menu is for setting up the digital recorder for motion recording on a per camera basis. In the **MOTION SETUP MENU** the following fields are defined as follows:

- **MOTION:** This field is to turn motion recording on or off. The Default from the factory is set to off or disabled. Motion is also considered an event. To change this, simply use the Jog Dial on the DVR to make your selection.

**ENABLE:** Enable motion detection.

**DISABLE:** Disable motion detection.

*Note: Motion only works in live and playback modes. It is invalid when you are setting menus.*

- **SENSITIVITY:** The sensitivity allows users to adjust to a suitable motion detection sensitivity. There are 10 sensitivities available; level 1 is the lowest, and level 10 is the highest sensitivity. To change this, simply use the Jog Dial on the DVR to make your selection.



➤ **LOG**

**YES:** Select **YES** if you wish to record Motion Events in the Log.

**NO:** Select **NO** if you do not wish to record Motion Events in the Log.

➤ **DURATION:** The amount of time a motion event will record - from 1 sec to 99 seconds. The default value is 5 seconds. To change this, simply use the Jog Dial on the DVR to make your selection.

➤ **ALARM OUTPUT:** This will transmit a signal to another device. The setting of alarms are **NONE = not activated, 1 = output signal 1 transmitted, 2 = output signal 2 transmitted, 3 = output signal 3 transmitted and 4 = output signal 4 transmitted.** To change this, simply use the Jog Dial on the DVR to make your selection.

➤ **ALARM EMAIL:**

**YES:** Send an email when an alarm occurs.

**NO:** Do not send an email when an alarm occurs

The email address and e-mail server can be set in the **NETWORK SETUP MENU.**

➤ **ALARM NETWORK:**

**YES:** Enable alarm network when an alarm occurs.

**NO:** Disable alarm network when an alarm occurs

➤ **BUZZER:** Audible buzzer when motion is detected.

**ENABLE:** To enable a motion buzzer.

**DISABLE:** To disable a motion buzzer.

➤ **MAIN MON:** Display on a main monitor when an alarm occurs.

**NO CHANGE:** No change on the display in the main monitor when a motion occurs.

**FULLSCREEN:** A full screen of the active camera will display when motion occurs.

- **CALL MON:** Display on a call monitor when motion occurs.  
**NO CHANGE:** No change on the display in the main monitor when motion occurs.  
**CAMERA 1~16 :** Display the active camera in full screen mode to the call monitor.
- **MATRIX MON 1:** Display on matrix monitor 1 when an alarm occurs.  
**NO CHANGE:** Nothing changes on the display in the matrix monitor 1 when an alarm occurs.  
**CAMERA 1~16:** Display an assigned camera in full screen mode to the matrix monitor 1.
- **MATRIX MON 2:** Display on matrix monitor 2 when an alarm occurs.  
**NO CHANGE:** Nothing changes on the display in the matrix monitor 2 when an alarm occurs.  
**CAMERA 1~16:** Display an assigned camera in full screen mode to the matrix monitor 2.
- **MATRIX MON 3:** Display on matrix monitor 3 when an alarm occurs.  
**NO CHANGE:** Nothing changes on the display in the matrix monitor 3 when an alarm occurs.  
**CAMERA 1~16:** Display an assigned camera in full screen mode to the matrix monitor 3.
- **MATRIX MON 4:** Display on matrix monitor 4 when an alarm occurs.  
**NO CHANGE:** Nothing changes on the display in the matrix monitor 4 when an alarm occurs.  
**CAMERA 1~16:** Display an assigned camera in full screen mode to the matrix monitor 4.
- **SUMMARY:** Dial **Jog** to change items in the **SUMMARY** table. All alarm's statuses are shown in **SUMMARY** tables. These tables are for checking alarm overall statuses, but not for setting.
- Press **SELECT** to Edit **MOTION AREA** Enter a desired channel and press **SELECT** to edit a motion area. Please make sure that **MOTION** is set as "**Enable**" before entering the motion detection area.

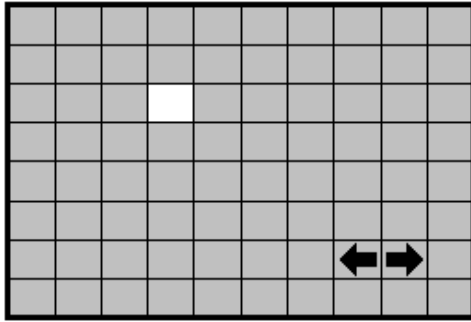



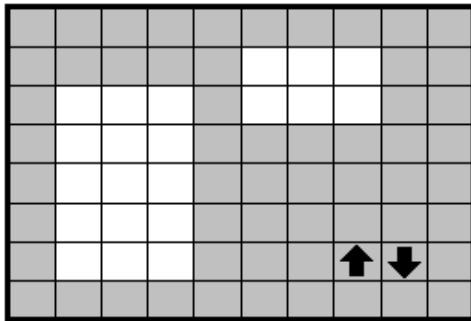

In the motion edit mode:

The default motion area of each camera is entire screen which displays in light green.

Press **COPY** or left-click the mouse to start setting an area.



Press **SEARCH** to end and enable the area, or press **PAUSE** to end and disable the area. Alternatively, right-click the mouse to obtain a selection menu, select "ON" to end and enable the area and "OFF" to end and disable the area by clicking on "+" or "-" sign. Then press "OK".

Dial **JOG** or scroll the tilt wheel of the mouse to select a horizontal  or a vertical  area to switch a horizontal  or vertical  area. To quit the motion area edit, press **MENU** or right-click the mouse to obtain a selection menu, select "EXIT" by clicking on "+" or "-" sign. Then press "OK".

- **To test a motion area:** Grids will turn into light red from light green when a motion is detected.
- **To clear the motion entire area:** Press **PLAY** to clear the entire motion area.
- **If you forget the motion grid commands:** Press **CALL** to get a hint window (shows below) in motion edit mode.

<b>MENU</b>	- <b>EXIT</b>
<b>COPY</b>	- <b>SELECT AREA</b>
<b>ENTER</b>	- <b>CHANGE DIR</b>
<b>SEARCH</b>	- <b>ON AREA</b>
<b>PAUSE</b>	- <b>OFF AREA</b>

### 3.6 VLoss Setup Menu



Diagram 3.9

Diagram 3.9 is a screen shot of the **VLOSS (Video Loss) SETUP MENU**. VLoss event is caused by no video signal input for the channel. Usually it happens when no power supply for the camera or the camera fails. How to set up system response for VLoss case is introduced in this section. In the **VLOSS (Video Loss) SETUP MENU** the following fields are defined as follows:

- **VLOSS:**
  - ENABLE:** Enable video loss detection.
  - DISABLE:** Disable video loss detection.
  
- **LOG**
  - YES:** Select **YES** if you wish to record Video Loss Events in the Log.
  - NO:** Select **NO** if you do not wish to record Video Loss Events in the Log.
  
- **DURATION:** The amount of time a vloss event will record - from 1 sec to 99 seconds. The default value is 5 seconds. To change this, simply use the Jog Dial on the DVR to make your selection.

- **ALARM OUTPUT:** This will transmit a signal to another device. The setting of alarms are **NONE = not activated, 1 = output signal 1 transmitted, 2 = output signal 2 transmitted, 3 = output signal 3 transmitted and 4 = output signal 4 transmitted.** To change this, simply use the Jog Dial on the DVR to make your selection.
  
- **ALARM EMAIL:** Select “**YES**” for sending an email when vloss occurs. The email address can be set in the **NETWORK SETUP MENU.**
  
- **BUZZER:** Audible alarm buzzer.  
  
**ENABLE:** To enable a vloss buzzer.  
  
**DISABLE:** To disable a vloss buzzer.
  
- **ALARM NETWORK:**  
  
**YES:** Enable alarm network.  
  
**NO:** Disable alarm network.
  
- **SUMMARY:** All video loss’s statuses are shown in **SUMMARY** tables. These tables are for checking video loss overall statuses, but not for setting.

## 3.7 Network Setup Menu

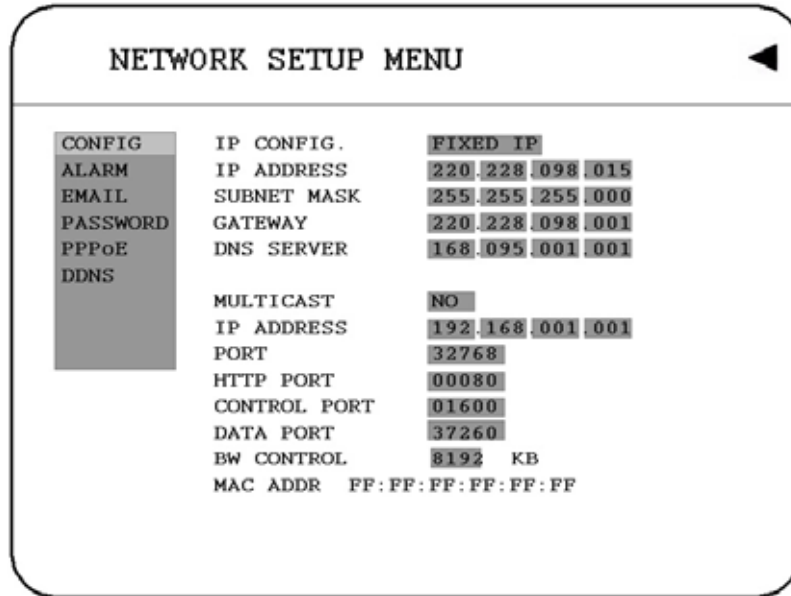

Diagram 3.10

Diagram 3.10 is a screen shot of the **NETWORK SETUP MENU**. This menu is for setting up the configurations for networking to the DVR. There are 6 subentries that are **CONFIG**, **ALARM**, **EMAIL**, **PASSWORD**, **PPPoE** and **DDNS** in the **NETWORK SETUP MENU**. Each of them has to be set up completely before the network functions. Please refer to the Networking Chapter of this manual to fully understand how to setup your network for this DVR. In the Network Setting Menu the following fields are defined as follows:

*Note: Since every Network Configuration is different, please contact your Network Administrator or ISP for how to assign those IP addresses and port numbers.*

### 3.7.1 CONFIG

In the **CONFIG** of the **NETWORK SETUP MENU**, we define:

➤ **IP CONFIG:**

**FIXED IP:** User can set the fixed IP for network connection..

**DHCP:** DHCP server in LAN will provide the dynamic IP for network connection

**PPPoE:** This is a DSL connection application, ISP will ask user for inputting user name and password. When you choose this option, please go to PPPoE configuration menu for setting PPPoE configuration.

- **IP Address:** This field is to set a static IP Address for the DVR. A static IP address is an IP address whose value does not change. It is suggested to use a static IP address. If your Internet provider does not offer a static IP address you have the option to use a dynamic IP address. For Example: A Test IP address given to the machine by our engineers is 192.168.010.002. When DHCP is YES, the DHCP server will assign this value automatically.
- **Note:** *The Addresses in the machine are for our own testing you must apply your own addresses to comply with your network. Refer to Networking Chapter for more details.*

To change this, simply use the Jog Dial on the DVR to make your selection.

- **SUBNET MASK:** This field is to set the subnet mask for your network so as the DVR will be recognized within the network. Example: 255.255.255.000. When DHCP is YES, the DHCP server will assign this value automatically. To change this, simply use the Jog Dial on the DVR to make your selection.
- **GATEWAY:** This field is to set the gateway for your network so the DVR will be recognized within the network. An example of this is provided within the DVR we use to test the machine within our own network. When DHCP is YES, the DHCP server will assign this value automatically. To change this, simply use the Jog Dial on the DVR to make your selection.
- **DNS SERVER:** This field is to set the DNS server for your network so the DVR will be recognized within the network. An example of this is provided within the DVR we use to test the machine within our own network. Assign a DNS server to DVR, for example: 168.195.001.001. When DHCP is YES, the DHCP server will assign this value automatically. To change this, simply use the Jog Dial on the DVR to make your selection.
- **MULTICAST:** This is network casting, it allows DVR to multi-cast through a router and this router will route to different end pints.

**YES:** to enable Multicast function.

**NO:** to disable Multicast function.

- **IP ADDRESS:** This is the router's IP address. Please input the IP address of router.
- **PORT:** Port of Multicast. Please configure the port number.
- **HTTP PORT:** The default port number is 80. User can change it to different port number for HTTP/WEB communication between DVR and client PC.
- **CONTROL PORT:** The default port number is 1600. User can change it to different port number for controlling comment between DVR and client PC.  
*Note: If you wish to have multiple users log into the DVR please open a range of ports on your router. For example if you use the default port 1600 you would open ports 1600 on your router. This will allow 4 clients to login*
- **DATA PORT:** The default data transmitting port number is 32760. User can change it to different port number for data transfer between DVR and client PC.  
*Note: If you wish to have multiple users log into the DVR please open a range of ports on your router. For example if you use the default port 32760 you would open ports 32760-32763 on your router. This will allow 4 clients to login*
- **BW CONTROL:** This configuration allows user to control the bandwidth of DVR.
- **MAC ADDR:** This field is for those Internet service providers or Network administrators who require a MAC address of the network card of our DVR. This option cannot be changed.



### 3.7.2 ALARM NETWORK (Reserved)

DVR can send out Alarm message to an Alarm Server (PowerCon4). This function is reserved to work with our Control Management System – PowerCon. In the **ALARM** of the **NETWORK SETUP MENU**, we define:

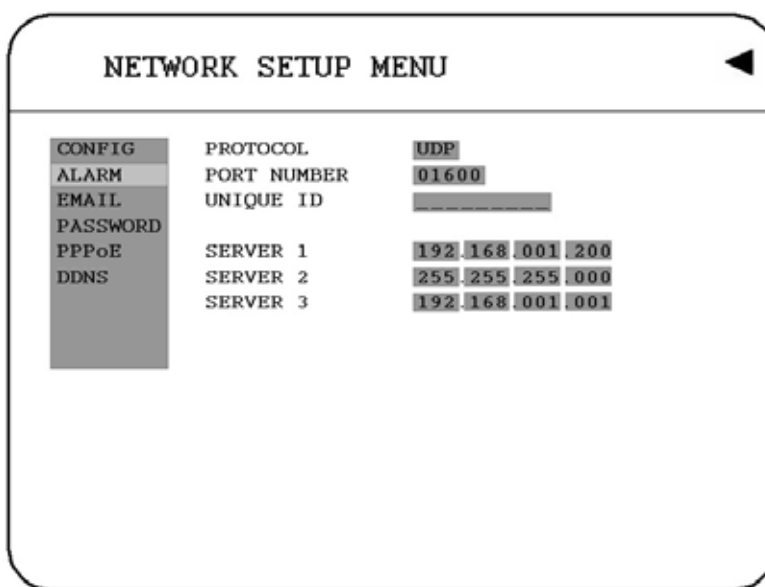

Diagram 3.11

*Note: Since every Network Configuration is different, please contact your Network Administrator or ISP for how to assign those IP addresses and port numbers.*

- **PROTOCOL:** Select which communication protocol with Alarm servers or Alarm receiving clients.  
  
TCP: communicate with client via TCP protocol.  
UDP: communicate with client via UDP protocol
- **PORT NUMBER:** setting the communication port with Alarm server.
- **UNIQUE ID:** setting the ID number of your DVR to Alarm server.
- **SERVER 1:** assign the IP address of Alarm server 1.
- **SERVER 2:** assign the IP address of Alarm server 2.
- **SERVER 3:** assign the IP address of Alarm server 3.

### 3.7.3 EMAIL

In the **EMAIL** of the **NETWORK SETUP MENU**, we define:

Menu Item	Field Name	Value
CONFIG ALARM EMAIL PASSWORD PPPoE DDNS	SMTP SERVER	[Empty]
	PORT NUMBER	00025
	AUTHENTICATION	NO
	USER	[Empty]
	PASSWD	[Empty]
	EMAIL ADDR	[Empty]

Diagram 3.12

- **SMTP SERVER:** assign the SMTP (e-mail) server's domain name. For example: mail.network.com.au.
- **PORT NUMBER:** assign the port number for SMTP server.
- **AUTHENTICATION:** select "YES", if the SMTP server requires Authentication (user name / password)
- **USER:** Input the login user ID if the SMTP server requires Authentication.
- **PASSWD:** Input the password if the SMTP server requires Authentication.
- **EMAIL ADDR:** Input the e-mail address for receiving e-mail message when the EVENT is enabled and triggered. For example: In Motion Setup Menu, if the "EMAIL/NETWORK" is set to "YES", this e-mail address will receive a text message and an "ARV" format of a still image from DVR when Motion is triggered. This "ARV" file can be played back by opening "DVRViewer.exe" that you downloaded from the DVR or the Remote Viewer (Browser) or from the Copy Menu (labeled viewer). In Alarm Setup Menu, if the "ALARM EMAIL" is

set to “YES”, this e-mail address will receive a text message and an “ARV” format of a still image from DVR when the Alarm is triggered. This “ARV” file can be played back by opening “DVRViewer.exe” that you downloaded from the DVR or the Remote Viewer (Browser) or from the Copy Menu (labeled viewer).

**Note:** If you are unable to play “AVI” file downloaded from “DVRViewer”, your PC is required to install “CODEC”, please go to the following URL:  
<http://www.divx.com/divx/play/download/index.php> for downloading DivXPlay.exe. This will enable you to play “AVI” file successfully.

### 3.7.4 PASSWORD

In the **PASSWORD** of the **NETWORK SETUP MENU**, we define:

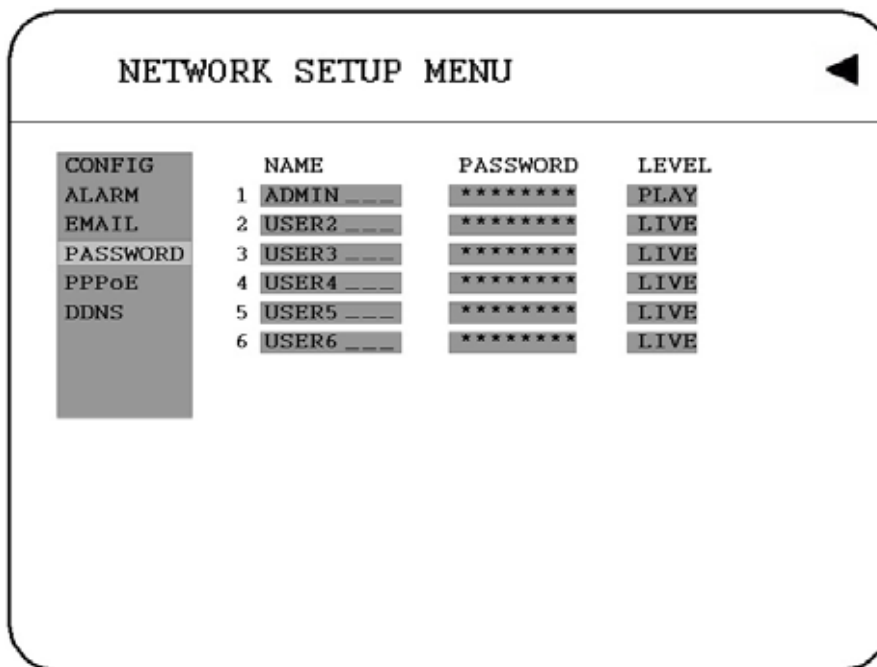

Diagram 3.13

- User-Name/Password/Level: This category is to set up the users that will log into the network. Please remember that this portion of the Network setting menu is set up in column format.

The default User Name = admin

The default Password = 11111111 (only numeric)

There are 2 level types:

- Play: Allows user to view live video, perform a search, playback and control the a PTZ camera (if one is connected)
- Live: Allows user only to view live video
  - To change this, simply use the Jog Dial on the DVR to make your selection.

Example:	USER-NAME	Password	Level
	admin	11111111	Play
Changed to	Adam	22222222	Play

- Please remember that there are only three different levels guest, general, and super.
  - “Admin” and “General” – can view live/playback video
  - “Guest” – can only view live.

### 3.7.5 PPPoE

In the PPPoE of the NETWORK SETUP MENU, we define :

The screenshot shows a menu titled "NETWORK SETUP MENU" with a back arrow in the top right corner. On the left, there is a vertical list of menu items: CONFIG, ALARM, EMAIL, PASSWORD, PPPoE (highlighted), and DDNS. To the right of this list, the PPPoE configuration fields are displayed:

USER	<input type="text"/>
PASSWD	<input type="text"/>
PRIMARY DNS	000.000.000.000
SECONDARY DNS	000.000.000.000

Diagram 3.14

- (1) **USER:** User name that is provided by ISP for PPPoE connection
- (2) **PASSWD:** Password that is provided by ISP for PPPoE connection
- (3) **PRIMARY DNS:** An IP address of DNS server that is provide by ISP.
- (4) **SECONDARY DNS:** If your ISP provides you an IP address secondary DNS, please set it in here.

**NOTE:** 1) Please complete all settings in **PPPoE** Setup Menu, then return to **CONFIG** for changing IP CONFIG to PPPoE. Otherwise, PPPoE settings won't be valid.

2) If you select first PPPoE in IP CONFIG of CONFIG option, while PPPoE settings haven't been done yet, then PPPoE function won't work.

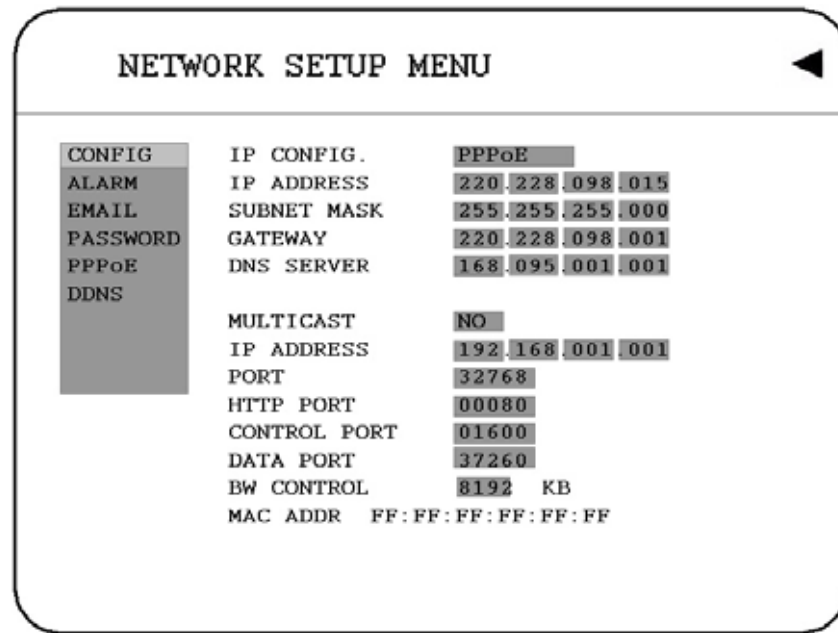

Diagram 3.15

### 3.7.6 DDNS

In **DDNS** of the **NETWORK SETUP MENU**, we define :

The screenshot shows a menu titled "NETWORK SETUP MENU" with a back arrow in the top right corner. On the left is a vertical list of menu items: CONFIG, ALARM, EMAIL, PASSWORD, PPPoE, and DDNS (which is highlighted). To the right of the DDNS menu item are several configuration fields:

SERVER	WWW.DYNDNS.ORG
USER	TEST
PASSWD	TEST
RECORD ID	
FQDN	ethin.dyndns.org

Diagram 3.16

For example: A user had applied for a DDNS account from [Http://www.dyndns.org](http://www.dyndns.org).

User name: TEST

Password: TEST

Domain name ethin.dyndns.org.

- (1) **SERVER:** DDNS provider.
- (2) **USER:** User name of the account.
- (3) **PASSWD:** Password of the account.
- (4) **RECORD ID:** Record ID.
- (5) **FQDN:** The domain name of this account.





Users can connect to DVR that uses dynamic IP address by entering the domain name “ethne.dyndns.org” in IE browser. They don’t have to know the IP address.

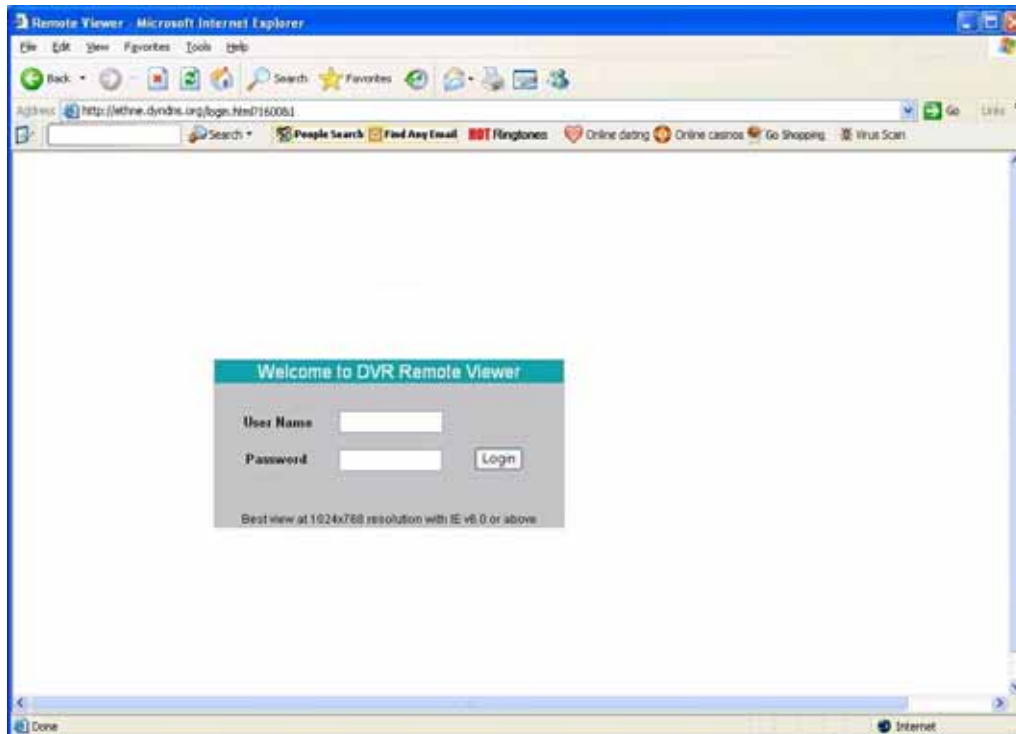

### 3.8 Schedule Setup Menu

TP	DAY	START	END	SET
1	WEND	08:00	12:00	ON
2	WDAY	08:00	17:00	ON
3	DLY	17:00	23:00	ON
4	DLY	00:00	00:00	OFF
5	DLY	00:00	00:00	OFF
6	DLY	00:00	00:00	OFF
7	DLY	00:00	00:00	OFF
8	DLY	00:00	00:00	OFF

DLY = DAILY  
WDAY = MON to FRI  
WEND = SAT and SUN

Diagram 3.17

Diagram 3.17 is a screen shot of the **SCHEDULE SETUP MENU**. In this menu you can set a unique timer any day of the week to start recording from a specified start time to an end time. This menu works together with the camera menu, you will notice 1~8 TP (time period), which is also seen in the camera menu. In the **SCHEDULE SETUP MENU** the following fields are defined as:

- **DAY:** This field represents the day of the week you wish to set the timer record for. Initially it is set to Sun as default. You may choose from Mon-Sun as well as DLY. If you wish to create a daily timer for every day of the week you may choose the DLY option. To change this, simply use the Jog Dial on the DVR to make your selection.

**MON** (Monday), **TUE** (Tuesday), **WED** (Wednesday), **THU** (Thursday), **FRI** (Friday), **SAT** (Saturday), **SUN** (Sunday).

**WDAY:** Weekday, from Monday to Friday.

**WEND:** Weekend, Saturday and Sunday.

**DLY:** Daily everyday of the week.

- **START:** This field is used to set the time you wish to start the timer recording. To change this, simply use the Jog Dial on the DVR to make your selection.

**Hour: 0 ~ 23** in 24 hour time format; **1~12** in 12 hour time format.

**Minutes: 00 ~ 59**

*Note: To record All day long: 12:00am~12:00 am for 12-hour-format  
00:00~00:00 for 24-hour-format*

- **END:** This field is used to set the time you wish to stop the timer recording. To change this, simply use the Jog Dial on the DVR to make your selection.

**Hour: 0 ~ 23** in 24 hour time format; **1~12** in 12 hour time format.

**Minutes: 00 ~ 59**

- **SET:** This field is used to turn the timer recording on or off. To change this, simply use the Jog Dial on the DVR to make your selection.

**ON:** Enable a scheduled record time period.

**OFF:** Disable a scheduled record time period.

### 3.9 Disk Setup Menu

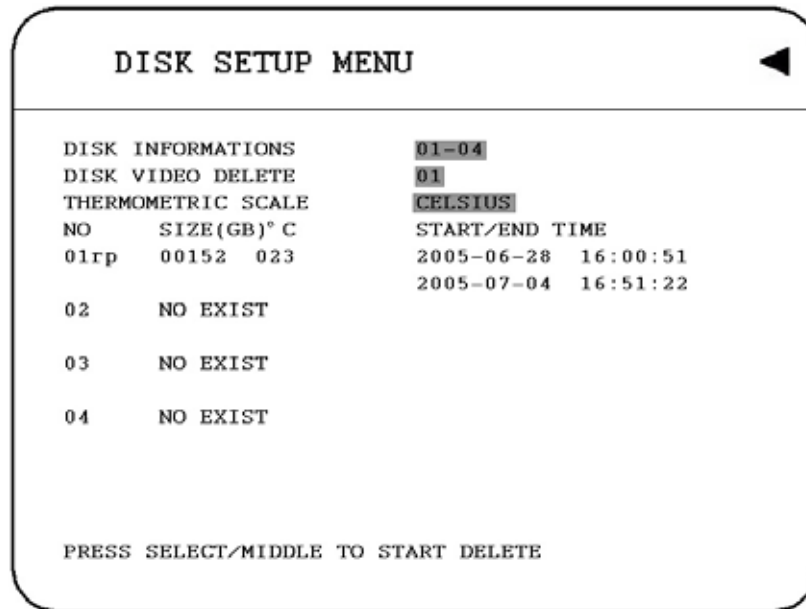

Diagram 3.18

Diagram 3.18 is a screen shot of the **DISK SETUP MENU**. This menu is for viewing Disk information and formatting the disks. For every configuration change or initial setup we recommend formatting the Hard Disk. In the **DISK SETUP MENU** the following fields are defined as follows:

- **DISK INFORMATIONS:** Select disks, there are 4 disks in each table. A maximum of 40 disks is available for this model.
- **DISK VIDEO DELETE:** Press **SELECT** to start delete. A delete disk confirmation window will show up after pressing **SELECT** button or tilt wheel of the mouse.

Dial the Jog to move highlighter to **YES**, and then press **SELECT** button or tilt wheel of the mouse; a deleting indicator **DELETE.....** will show up.

If you do not want to delete the disk after the delete disk confirmation window shows up, you can move highlighter to **NO**, and then press **SELECT** or tilt wheel of the mouse to quit.

An indicator of success **SUCCESS.....** show up when delete is completed.

**Note:** System will ask you to stop recording if you delete the disk when system is in the recording mode.

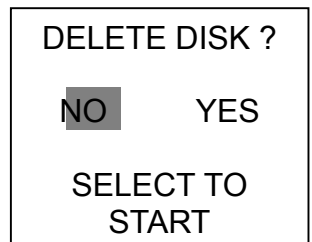

- **THERMOMETRIC SCALE:** Select **CELSIUS** or **FAHRENHEIT** for thermometric scale of the disk.
  
- **NO/SIZE/C or F/Start/End Time:** Show the number of drives the size of each drive and the temperature as well as the days and times range stored on the hard drive.

### 3.10 Control Setup Menu

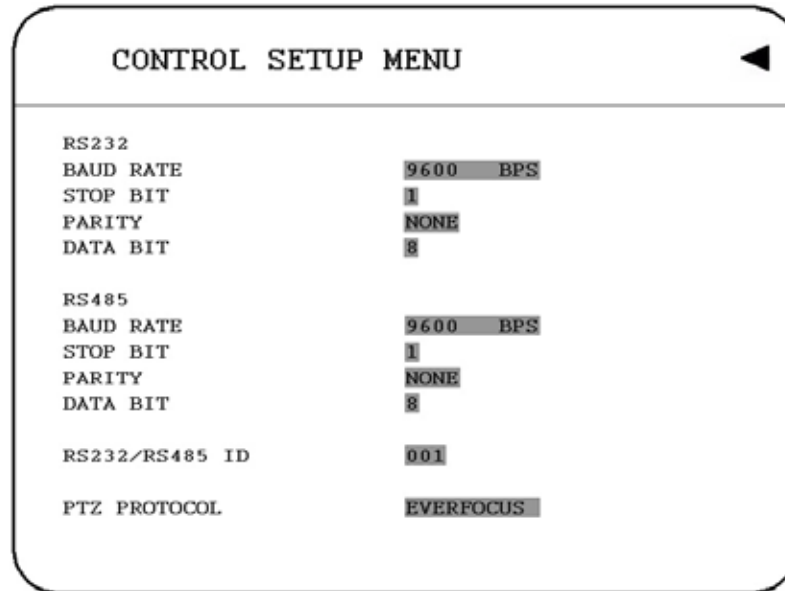

Diagram 3.19

Diagram 3.19 is a screen shot of the Control Setting Menu. This menu is for setting up a connection from the digital recorder to a computer to transfer instructions or information using the HyperTerminal program in Windows. In the Control Setting Menu the following fields are defined as follows:

#### RS232:

- **RS232 Baud Rate:** This field is to set the speed at which is used to transmit instruction or information through the RS232 port on the DVR. There are six different speeds, 1200 BPS, 2400 BPS, 4800 BPS, 9600 BPS, 19200 BPS, and 3840 BPS. The default setting from the factory is 9600 BPS. To change this, simply use the Jog Dial on the DVR to make your selection.
- **RS232 Stop Bit:** This field is to set the stop bit for the RS232 connection. There are two different stop bits, 1 or 2. The default in the DVR is set to 1. To change this, simply use the Jog Dial on the DVR to make your selection.
- **RS232 Parity:** This field is to select the parity level at which you will be connected. You can choose between None, Odd, or Even parity levels. Default is set to none. To change this, simply use the Jog Dial on the DVR to make your selection.

- **RS232 Data Bit:** This field is the data bit at which you will be transferring. There are two settings for this option: 8 or 7. The default is set to 8. To change this, simply use the Jog Dial on the DVR to make your selection.

#### **RS485:**

- **RS485 Baud Rate:** This field is to set the speed at which is used to transmit instruction or information through the RS485 port on the DVR. There are six different speeds, **2400, 4800, 9600, 19200, 38400** and **57600**BPS. The default setting from the factory is 9600 BPS. To change this, simply use the Jog Dial on the DVR to make your selection.
- **RS485 Stop Bit:** This field is to set the stop bit for the RS485 connection. There are two different stop bits, 1 or 2. The default in the DVR is set to 1. To change this, simply use the Jog Dial on the DVR to make your selection.
- **RS485 Parity:** This field is to select the parity level at which you will be connected. You can choose between None, Odd, or Even parity levels. Default is set to none. To change this, simply use the Jog Dial on the DVR to make your selection.
- **RS485 Data Bit:** This field is the data bit at which you will be transferring. There are two settings for this option: 8 or 7. The default is set to 8. To change this, simply use the Jog Dial on the DVR to make your selection.
- **RS232/RS485 ID:** This entry is used to assign each device its own ID code if more than one unit is used through the RS232/RS485 connection. There are two ID codes for the DVR: 001-255. The default is set to 001. To change this, simply use the Jog Dial on the DVR to make your selection.
- **PTZ PROTOCOL:** Select PTZ protocol from **EVERFOCUS, PELCO-D, PELCO-P** and **ED2200/2250**.

### 3.11 Warning Setup Menu

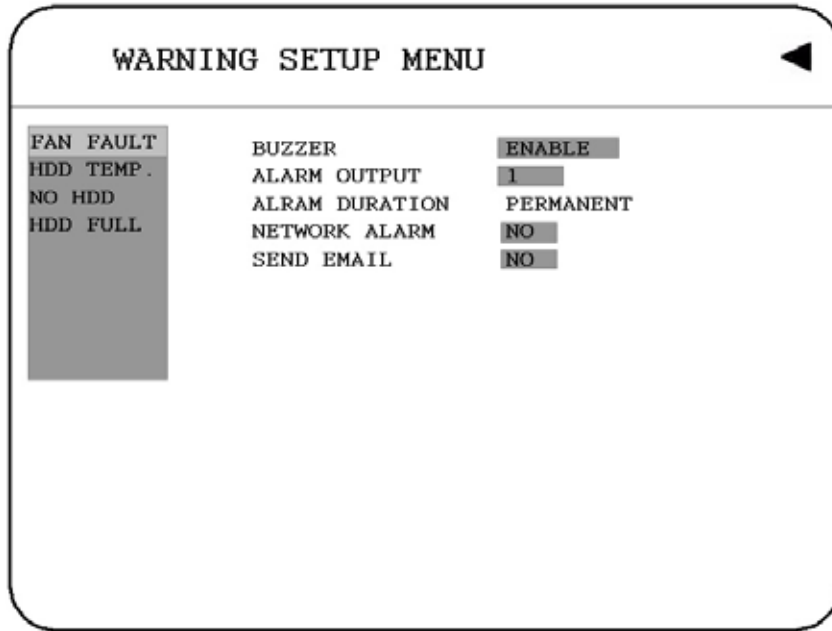

Diagram 3.20

Diagram 3.20 is a screen shot of the **Warning Setup Menu**. This menu is to set the warning system settings. If any critical errors were to arise, this portion of the menu would be for error handling. For example if you set the fan buzzer on and the fan wasn't able to turn on then you would here an alarm go off. In the **Warning Setup Menu** the following fields are defined as:

#### 3.11.1 FAN FAULT

In **FAN FAULT**, we define:

- **BUZZER:** Fan buzzer. To change this, simply use the Jog Dial on the DVR to make your selection.  
  
**ENABLE:** To enable a buzzer when the fan does not work.  
  
**DISABLE:** To disable fan buzzer.
- **ALARM OUTPUT:** This will transmit a signal to another device. The setting of alarms are **NONE = not activated, 1 = output signal 1 transmitted, 2 = output signal 2 transmitted, 3 = output signal 3 transmitted and 4 = output signal 4 transmitted**. To change this, simply use the Jog Dial on the DVR to make your selection.



➤ **ALARM DURATION:** Permanent

➤ **NETWORK ALARM:**

**YES:** To enable network alarm.

**NO:** To disable network alarm.

➤ **SEND EMAIL:**

**YES:** Send an email when the fan does not work.

**NO:** Do not send an email when the fan does not work.

The email address can be set in the **NETWORK SETUP MENU**.

### 3.11.2 HDD TEMP

In **HDD TEMP**, we define:

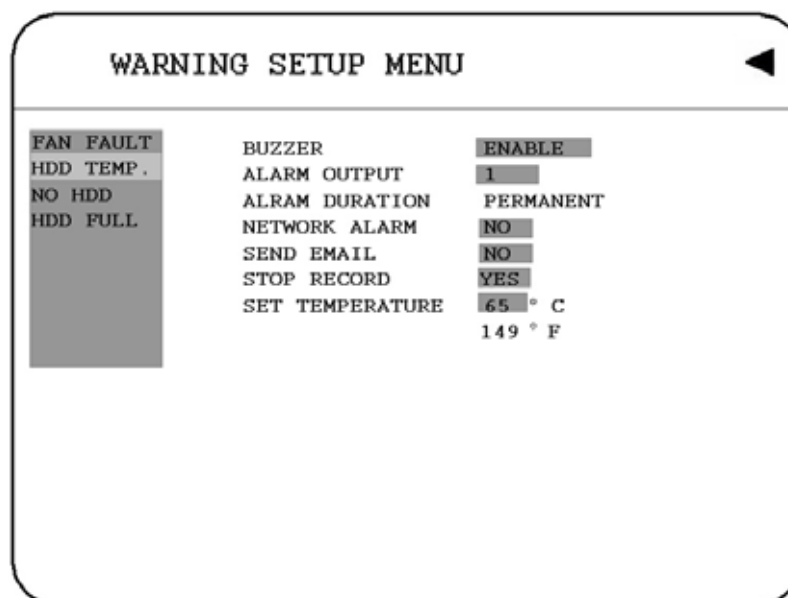

Diagram 3.21

- **BUZZER:** HDD TEMPERATURE buzzer.

**ENABLE:** To enable a buzzer when HDD's temperature is higher than the temperature set in "SET TEMPERATURE".

**DISABLE:** To disable HDD TEMP. Buzzer.

- **ALARM OUTPUT:** This will transmit a signal to another device. The setting of alarms are **NONE = not activated, 1 = output signal 1 transmitted, 2 = output signal 2 transmitted, 3 = output signal 3 transmitted and 4 = output signal 4 transmitted.** To change this, simply use the Jog Dial on the DVR to make your selection.

- **ALARM DURATION:** Permanent

- **NETWORK ALARM:**

**YES:** To enable network alarm.

**NO:** To disable network alarm.

- **SEND EMAIL:**

**YES:** Send an email when HDD's temperature is overheated.

**NO:** Will not send an email when HDD's temperature is overheated.

The email address can be set in the **NETWORK SETUP MENU**.

➤ **STOP RECORD:**

**YES:** Stop recording when HDD's temperature is overheated.

**NO:** Will not stop recording even when HDD's temperature is overheated.

➤ **SET TEMPERATURE:**

It is possible to set temperature, when HDD's temperature is higher than the degree you set, then all other setting in HDD TEMP. will take effect (BUZZER, ALARM OUTPUT, ALARM DURATION, NETWORK ALARM, SEND EMAIL, STOP RECORD).

### 3.11.3 NO HDD

In **NO HDD**, we define:

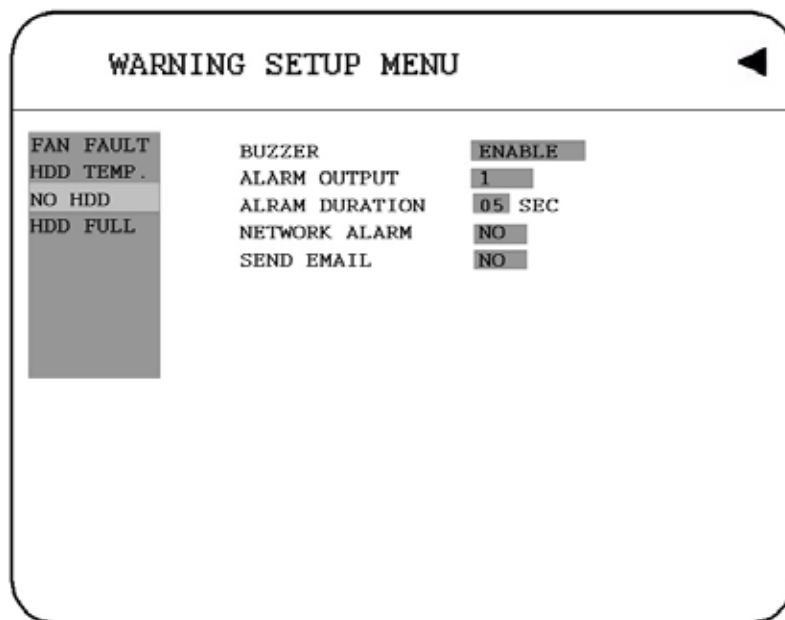

Diagram 3.22

- **BUZZER:** NO HDD buzzer.
  - ENABLE:** To enable a buzzer when no HDD has been found.
  - DISABLE:** To disable NO HDD buzzer.
- **ALARM OUTPUT:** This will transmit a signal to another device. The setting of alarms are **NONE = not activated, 1 = output signal 1 transmitted, 2 = output signal 2 transmitted, 3 = output signal 3 transmitted and 4 = output signal 4 transmitted.** To change this, simply use the Jog Dial on the DVR to make your selection.
- **ALARM DURATION:** Buzzer noise and event record duration of an alarm, from 1 sec to 99 seconds. The default value is 5 seconds.
- **NETWORK ALARM:**
  - YES:** To enable network alarm.
  - NO:** To disable network alarm.

➤ **SEND EMAIL:**

**YES:** Send an email when no HDD has been found.

**NO:** Will not send an email when no HDD has been found.

The email address can be set in the **NETWORK SETUP MENU**.

### 3.11.4 HDD FULL

In **HDD FULL**, we define:

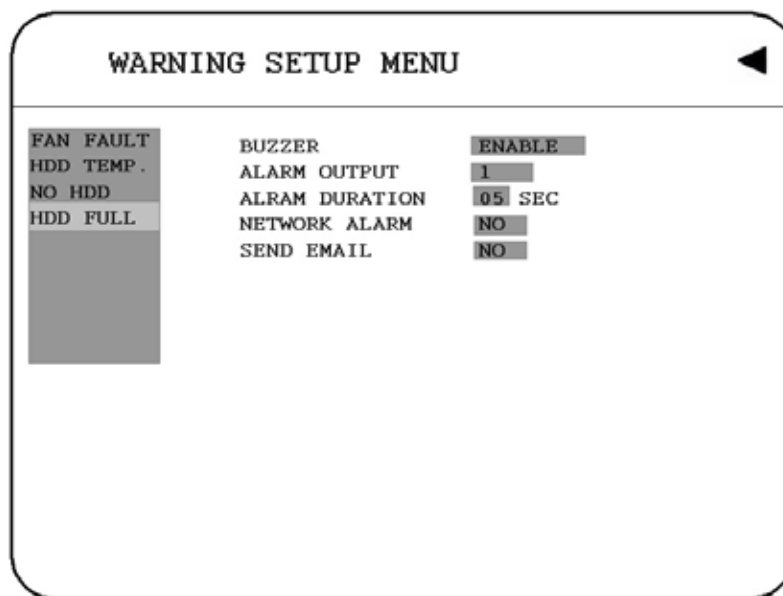

Diagram 3.23

➤ **BUZZER:** HDD FULL buzzer.

**ENABLE:** To enable a buzzer when HDD is full.

**DISABLE:** To disable HDD Full buzzer.

- **ALARM OUTPUT:** This will transmit a signal to another device. The setting of alarms are **NONE = not activated, 1 = output signal 1 transmitted, 2 = output signal 2 transmitted, 3 = output signal 3 transmitted and 4 = output signal 4 transmitted.** To change this, simply use the Jog Dial on the DVR to make your selection.
  
- **ALARM DURATION:** Buzzer noise and event record duration of an alarm, from 1 sec to 99 seconds. The default value is 5 seconds.
  
- **NETWORK ALARM:**
  - YES:** To enable network alarm.
  - NO:** To disable network alarm.
  
- **SEND EMAIL:**
  - YES:** Send an email when HDD is full.
  - NO:** Will not send an email when HDD is full.

The email address can be set in the **NETWORK SETUP MENU.**

### 3.12 System Setup Menu

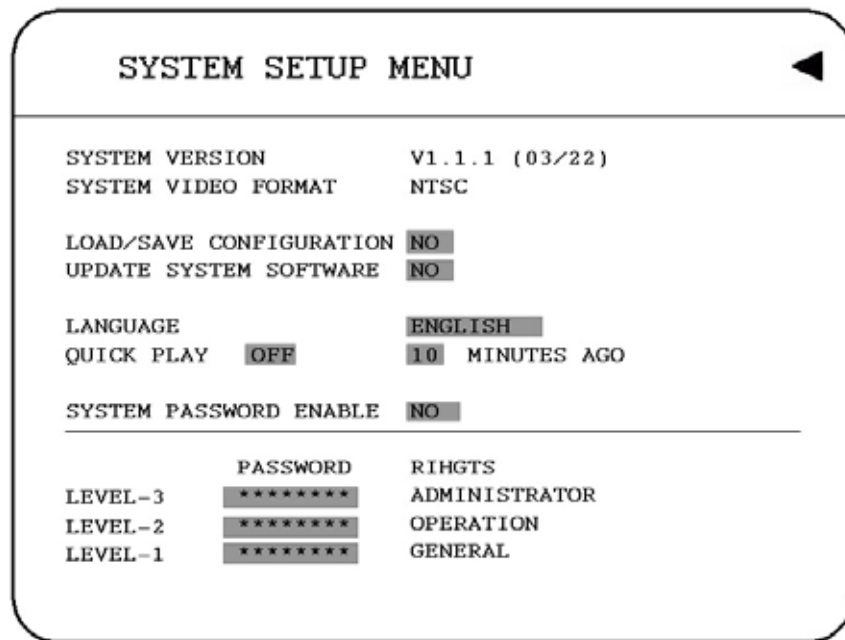

Diagram 3.24

Diagram 3.24 is a screen shot of the **SYSTEM SETUP MENU**. This menu is for setting up any additional options and restoring defaults to the digital recorder. In the **SYSTEM SETUP MENU** the following fields are defined as follows:

- **SYSTEM VERSION:** Current system firmware version.
- **SYSTEM VIDEO FORMAT:** NTSC or PAL. System can detect the input signal type automatically from camera 1 while system is booting up. Users do not need to set it up.

*Note: The signal type is detected by the camera 1, so camera 1 input has to be connected.*

- **LOAD/SAVE CONFIGURATION:**

**YES:** Turn the jog to enter the selection window, there are 4 options available: **CANCEL**, **DEFAULT**, **LOAD**, and **SAVE**. Select “CANCEL” for leaving the existing window. Select “DEFAULT” to load factory default values. Select “LOAD” to upload and save DVR configuration settings from USB. Select “SAVE” to save existing DVR configuration settings to USB device. Press “SELECT” button from the front panel to confirm once the selection is made. Note that a USB device has to be

inserted properly before choosing “LOAD” or “SAVE” options. System will ask you to stop recording if you confirm to load default setting, to load saved setting or to save existing setting when the system is recording.

➤ **UPDATE SYSTEM SOFTWARE:** Turn the jog to enter the selection window.

**YES:** Select **YES** to update system software from USB by pressing **SELECT** or tilt wheel of the mouse to start.

**NO:** Select **NO** for canceling updating by pressing **SELECT** or tilt wheel of the mouse to start.

*Note: 1. System will ask you to stop recording if you confirm to update when system is recording.*

*2. USB device must be inserted properly before updating system software.*

*3. Do not remove USB device when you are updating system software, it may cause crash to the machine.*

➤ **CALL MON QUAD SEQ:** The dwell period of the call monitor quad display in the sequence mode.

*Note: Please refer to CALL setting for an advanced call monitor setting.*

➤ **LANGUAGE:** System language can be set in different languages. The available language depend on the country or area. Subject to change without further notice. Please consult your sales representative for the most update information.

➤ **QUICK PLAY:** Allows the user to press the play button and playback video from the time indicated from this field (0 ~ 59 Min).

**ON:** Enable quick play. The video played time is the immediate play time from now.

**OFF:** Disable quick play. Videos will start to be played from the end point of the last play.

**TIME:** Quick play time, from 1 ~ 59 min. The default value is 10 minutes.

**Note:** The recommendatory quick play time is 10 minutes. The video cannot be played due to the video file is not stored to HDD yet if you set a quick play time too short.

➤ **SYSTEM PASSWORD ENABLE:**



**YES:** Select **YES** to enable the password function.

**NO:** Select **NO** to disable the password function.

- **PASSWORD and RIGHTS:** The login passwords here are used to operate and set up this machine locally not from the remote tcp/ip connection. The different login passwords indicate the different level of users, and no login name is necessary. The digit will appear instead of a “\*” sign when the cursor is moved on it. Turn the Jog to change the digit on which the cursor is located of the password, and press **ENTER/CALL** to go next/last digit. The available digits are **1, 2, 3, 4, 5, 6, 7, 8** and **9**. There are three system access levels and one none access level. The below chart on the next page shows the rights of each level.

- *Note: If the passwords of different levels are set the same, you will enter a higher level when you login. For example, you will login to the **ADMINISTRATOR** level if the password of **ADMINISTRATOR** and **GENERAL** levels are the same.*

- *Note: If you enable the system password levels and are logged in any level higher than Level 1 with no action having taken place after 20 seconds the DVR will automatically log you back into Level 1.*

- *Note: After operation by a higher level user, please go back to camera live state and wait for one minute to activate system password for another user.*

- *Note: After upgrading system software, please do the following actions before recording:*

1. Load System Default in **System Setup Menu**.
2. Delete disk in **Disk Setup Menu**.

<b>User Level and Right</b>				
<b>LEVEL</b>	<b>LEVEL-3</b>	<b>LEVEL-2</b>	<b>LEVEL-1</b>	<b>NONE ACCESS</b>
	<b>ADMINISTRATOR</b>	<b>OPERATOR</b>	<b>GENERAL</b>	<b>----</b>
<b>DISPLAY</b>	<b>OK</b>	<b>OK</b>	<b>OK</b>	<b>OK</b>
<b>MODE</b>	<b>OK</b>	<b>OK</b>	<b>OK</b>	<b>OK</b>
<b>ZOOM</b>	<b>OK</b>	<b>OK</b>	<b>OK</b>	<b>OK</b>
<b>SELECT</b>	<b>OK</b>	<b>OK</b>	<b>OK</b>	<b>NO</b>
<b>SEQ</b>	<b>OK</b>	<b>OK</b>	<b>OK</b>	<b>NO</b>
<b>CALL</b>	<b>OK</b>	<b>OK</b>	<b>NO</b>	<b>NO</b>
<b>MENU</b>	<b>OK</b>	<b>NO</b>	<b>NO</b>	<b>NO</b>
<b>COPY</b>	<b>OK</b>	<b>NO</b>	<b>NO</b>	<b>NO</b>
<b>SEARCH</b>	<b>OK</b>	<b>NO</b>	<b>NO</b>	<b>NO</b>
<b>PLAY</b>	<b>OK</b>	<b>NO</b>	<b>NO</b>	<b>NO</b>
<b>STOP</b>	<b>OK</b>	<b>NO</b>	<b>NO</b>	<b>NO</b>
<b>REC</b>	<b>OK</b>	<b>NO</b>	<b>NO</b>	<b>NO</b>
<b>PAUSE</b>	<b>OK</b>	<b>NO</b>	<b>NO</b>	<b>NO</b>

*Note: The above table will be updated if there is any change.*

## 4. Recording Overview

Before continuing with the Recording Overview please be sure to have reviewed DVR Menu Setup (Chapter 3) specifically the camera & schedule. You are now ready to begin setting up the machine for recording. This chapter will show you how to setup the recorder for three basic types of recording: Instant recording, scheduled recording, and event recording. **Instant recording (N)** is simple as it sounds its instantaneous, basically manually pressing the record button for recording, much like pressing the record button on a VCR. **Scheduled recording (1~8)** is based upon a set time period of when to begin & end the recording. **Event recording** would consist of an alarm, Vloss or motion having taken place to trigger the DVR to record on that event.

### 4.1 Instant (N) Recording Setup

- Press the Record key to start recording immediately.



**REC**

When **REC** is pressed, the pictures being monitored will be recorded in the HDD.

- The recording rate, recording quality and recording speed can be set in the **CAMERA SETUP MENU**. To set the target camera for a particular recording speed /IPS (when using the instant record method). Apply the changes to the last Time Period (TP) row labeled **N**
- A “RECORD” sign appears in the record status bar.



**STOP**

Press **STOP** key to stop instant recording.

- The **STOP** key can be activated only in instant recording mode, but not available in the schedule or event recording mode.
- When the HDD is full, the machine will stop recording automatically or overwrite from the beginning of the HDD. It depends on the setting in the **RECORD SETUP MENU**.

*Note: 1. If STOP key is pressed while machine is recording or playing video, the playing function will be disabled first. If STOP key is pressed twice the DVR will come out of record mode completely.*

*2. We suggest not to remove the Hot-Swappable Drive while the machine is recording or in playback. Please stop any type of recording or playback first before removing the Hot-Swappable Drive.*

## 4.2 Schedule Recording Setup

- Set up the **DAY**, **START** time, **END** time and then enable the **SET** in the **SCHEDULE SETUP MENU**.

TP	DAY	START	END	SET
1	WEND	08:00	12:00	ON
2	WDAY	08:00	17:00	ON
3	DLY	17:00	23:00	ON
4	DLY	00:00	00:00	OFF
5	DLY	00:00	00:00	OFF
6	DLY	00:00	00:00	OFF
7	DLY	00:00	00:00	OFF
8	DLY	00:00	00:00	OFF

DLY = DAILY  
WDAY = MON to FRI  
WEND = SAT and SUN

Diagram 4.1

- Please refer to **SCHEDULE SETUP MENU**, to see setting procedure and more details (Chapter 3.8).

### 4.3 Event Recording Setup

- We will define two event recording types **ALARM** and **MOTION**. After the event recording is enabled, the DVR will start an event recording when an event occurs. For instance when motion activity is detected by the DVR it will begin recording at the specific IPS set under event column. Or when an alarm is detected by the DVR it will begin recording at the specific IPS set under event column.
- In order to start an event recording, you will **NEED** to perform the following:
  1. Enable the event in each event (alarm or motion menu) setting first. For example (motion), enable Camera 2 in the **MOTION SETUP MENU** (shown as below). You can enable multiple alarm or motion triggers.

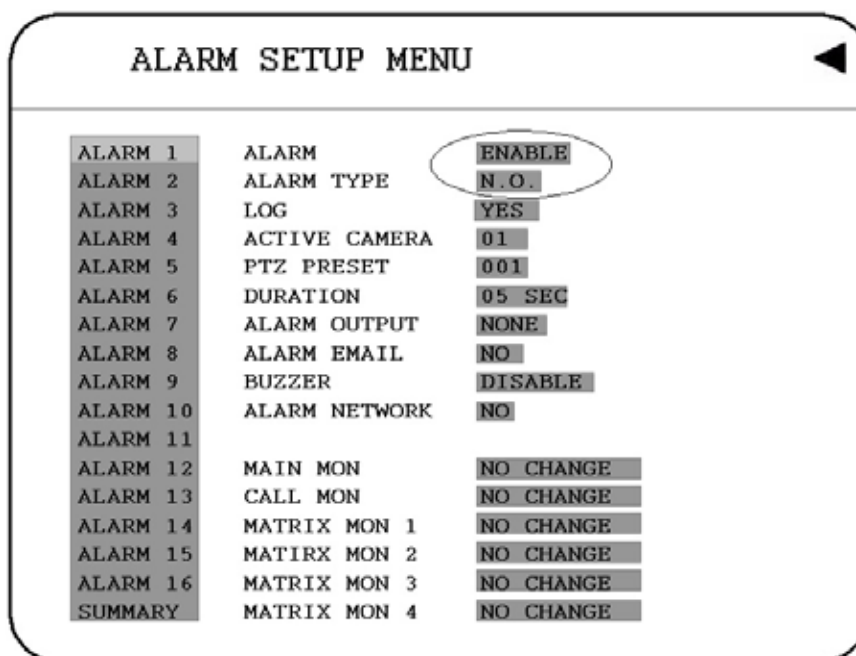

Diagram 4.2

2. After enabling an event, you need to set a time period (TP) in the **SCHEDULE SETUP MENU**. An event recording must be set in a scheduled time period (TP). You can refer to the **SCHEDULE SETUP MENU** for time period configurations (Chapter 3.8).

TP	DAY	START	END	SET
1	WEND	08:00	12:00	ON
2	WDAY	08:00	17:00	ON
3	DLY	17:00	23:00	ON
4	DLY	00:00	00:00	OFF
5	DLY	00:00	00:00	OFF
6	DLY	00:00	00:00	OFF
7	DLY	00:00	00:00	OFF
8	DLY	00:00	00:00	OFF

DLY	=	DAILY
WDAY	=	MON to FRI
WEND	=	SAT and SUN

Diagram 4.3

- When the event and schedule are set, enter the **CAMERA SETUP MENU** to set the event recording speed (IPS) of the camera in the time period (TP) section.

CAMERA SETUP MENU			
CAMERA 1	TITLE	CH01	
CAMERA 2	PTZ ID	011	
CAMERA 3	INSTALL/COVERT	ON /OFF	
CAMERA 4	SEQ(MAIN/CALL)	03/03 SECS	
CAMERA 5	REC QUALITY	HIGH	
CAMERA 6			
CAMERA 7	REC SPEED ON TIME ZONE		
CAMERA 8	TP NORMAL	EVENT	SET
CAMERA 9	1 1 IPS	30 IPS	OFF
CAMERA 10	2 1 IPS	30 IPS	OFF
CAMERA 11	3 1 IPS	30 IPS	OFF
CAMERA 12	4 1 IPS	30 IPS	OFF
CAMERA 13	5 1 IPS	30 IPS	OFF
CAMERA 14	6 1 IPS	30 IPS	OFF
CAMERA 15	7 1 IPS	30 IPS	OFF
CAMERA 16	8 1 IPS	30 IPS	OFF
SUMMARY	N 1 IPS	30 IPS	OFF

Diagram 4.4

**Note:** Set the time period (TP) from 00:00 to 00:00 daily in the **SCHEDULE SETUP MENU**, and set the normal record speed as 0 IPS in the **CAMERA SETUP MENU** if you only want to record only on an events activity recording (motion or alarm).

- The DVR provides a record function which is triggered by external signal via the 19th pin of the **ALARM INPUT / OUTPUT** port. When the record input signal is pulled low constantly, DVR will start to record. The system will stop recording when the record input signal is not pulled low.

**Note:** Please check **APPENDIX C** to see other available alarm input/output functions.

## 5. Playback Overview

Before continuing please be sure to have reviewed DVR Menu Setup (Chapter 3). You are now ready to begin setting up the DVR for playback. This chapter will show you how to setup the recorder for basic playback.

### 5.1 Basic Playback

#### (1) Playback



PLAY

Press the **PLAY** key to start playing back the stored image/audio. The video start time depends on the quick play setting in the **SYSTEM SETUP MENU**. The DVR is duplex, which means you can record and playback the same time.



REV.PLAY

Press the **REV. PLAY** key and the DVR will rewind while displaying video in reverse.

#### (2) STOP



STOP

Press the **STOP** key to stop playing back.



### (3) Fast Forward/Reverse Playback



**PLAY**

Press the **PLAY** key to begin playing back process.

Turn the **Shuttle** dial clockwise, to begin fast forward playback.

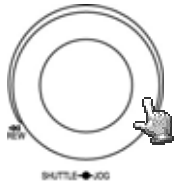

The speed will be shown on the status bar of the bottom screen.

>> **2, 4, 6, 8, 16, 32, 600X**, and press **ENTER** at the same time to hold the play speed. The enter button will lock the X speed that is desired or you can manually hold the shuttle dial in the position.

Press **PLAY** again to return normal play speed.

Turn the **Shuttle** dial counterclockwise, to start fast reverse playback.

The speed will be shown on the status bar of the bottom screen.

<< **2, 4, 6, 8, 16, 32, 600X**, and press **ENTER** at the same time to hold the play speed. The enter button will lock the X speed that is desired or you can manually hold the shuttle dial in the position.

Press **PLAY** again to return normal play speed.

### (4) Slow Forward/Reverse Playback



**PAUSE**

During playback mode, press **PAUSE** key to freeze the playing back picture.

Turn the **Shuttle** dial clockwise, to start slow forward playback.

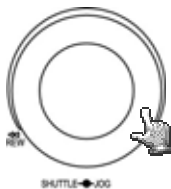

The speed will show on the status bar of the bottom screen.

>> **1/2, 1/4, 1/8, 1/16, 1/32, 1/600** and press **ENTER** at the same time to hold the play speed. The enter button will lock the X speed that is desired or you can manually hold the shuttle dial in the position.

### (5) Image advance Forward/Reverse



**PAUSE**

Press **PAUSE** key to freeze the picture.



Turn the **Jog** dial clockwise to advance the still video image by image.

Turn the **Jog** dial counterclockwise to rewind the still video image by image.

The field feed speed will increase if the **Jog** dial is turned quickly.

## 5.2 Search Playback



**SEARCH**

Press the **SEARCH** key to enter the **SEARCH MENU**.

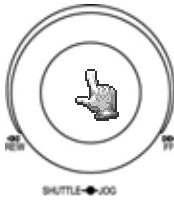

In the **SEARCH MENU**,  
Dial the **Jog** clockwise or counterclockwise to change subentry values.

Press the **ENTER** key to go next subentry in search menu setting,  
and press the **CALL** key to go last subentry in search menu setting.

Press **MENU** to exit.

Press **SELECT** or tilt wheel of the mouse to start search.

Press **SELECT** to start search.

### (1) TIME / DATE Search Playback

The following window will show up after pressing **SEARCH** key. Select “**BY TIME / DATE**”, and then select the time you want to search. Press **SELECT**, the system will start to search.

**SEARCH MENU**

---

METHOD	<b>BY EVENT</b>		
DATE	<b>2005-10-05 WED</b>		
TIME	<b>00:41:00</b>		
EVENT	<b>A/M/V</b>		
DISK NO	<b>01</b>		
NO	SIZE(GB)	° F	START/END TIME
01rp	00115	118	2005-06-28 16:00:51
			2005-07-04 16:51:11

PRESS MENU TO EXIT  
PRESS SELECT/MIDDLE TO START SEARCH

Diagram 5.1

An **EVENT** search does not give you the option to change the “**BY TIME / DATE**” search method. Size of total data file, HDD temperature, start recording time and end recording time of the disk show in the search screen.

**Note:** If there is no video stored in the date/time specified, then the image will keep at the end of the last play, and the display time on the status bar shows “??:??”.

## (2) **EVENT Search Playback**

You can change different event search methods if you select “**BY EVENT**” instead of “**BY TIME / DATE**”. 7 events which are **ALARM**, **MOTION**, **VLOSS**, **A/M**, **A/V**, **M/V** and **A/M/V** can be selected.

The indications of events show as below.

<b>EVENT</b>	<b>Indication</b>
<b>ALARM</b>	Search ALARM events
<b>MOTION</b>	Search MOTION events
<b>VLOSS</b>	Search video loss events
<b>A / M</b>	Search ALARM and MOTION events
<b>A / V</b>	Search ALARM and video loss events
<b>M / V</b>	Search MOTION and video loss events
<b>A / M / V</b>	Search all events (ALARM, MOTION and video loss)

(3) **DATE** and **TIME** are not able to be changed in the **EVENT** search method. The search list shows up when **SELECT** key is pressed. There are 16 events in one page, and current page / total pages shows on the top. Dial **Shuttle** clockwise or press **COPY** for moving to next page; dial **Shuttle** counterclockwise or press **CALL** for moving to previous page. If you would like to jump to a specific page directly, you can press **Search**, then dial **Jog** to the page, and press **Enter**. Dial the **Jog** to change events on the event list; the selected item will be highlighted. Press **ENTER** to play the selected event.

SEARCH LIST OF DISK 01 P.001/201			
00001	M01	2005-06-27	16:33:05
00002	V03	2005-06-27	17:31:11
00003	V06	2005-06-27	19:47:25
00004	V08	2005-06-27	19:51:32
00005	PL	2005-06-28	06:32:17
00006	RTN	2005-06-28	09:58:41
00007	A04	2005-06-29	16:18:58
00008	T2	2005-06-29	17:54:35
00009	M04	2005-06-29	20:31:11
00010	A04	2005-06-29	23:23:11
00011	TN	2005-07-01	10:51:03
00012	M07	2005-07-01	16:21:11
00013	M03	2005-07-03	06:43:16
00014	PL	2005-07-03	12:51:51
00015	RT2	2005-07-03	13:01:44
00016	M01	2005-07-04	16:58:55

GO TO SEARCH PAGE:006

The event types and number show on the second column of the search list. Where

- An:** an Alarm event. the "n"th Alarm input.
- Dn:** HDD overheated, overheat temperature is based on HDD temperature set in Warning Setup Menu.
- Fn:** Fan fail, n = 1~3 fan number.
- LH:** (Logical Head): Beginning of recording date & time right after HDD has been overwritten.
- LUn:** Local User login record, n = 1~3, access level; where 1 is Administrator, 2 is Operator and 3 is General.
- Mn:** a Motion event. n: the channel Number.
- PH:** (Physical Head): which is the beginning point of HDD's space.
- PL:** a Power Loss event.
- RTn:** a power ReTurn event in a schedule recording mode, "REC TP= n =1~8.
- RTN:** a power ReTurn event in a Normal/instant recording mode.
- RUn:** record of Remote User login through IE, n = 1~6, access level of users.
- Tn:** a schedule Time period recording event, "REC TP"=1~8; Time Period 1~8.
- TN:** a Normal/instant Time recording event. "REC TP=N" ; Normal Recording.
- Vn:** a Video loss event. the "n"th Alarm input.

The number after letter indicates the number of even type. The last two columns are the date and time of event.

## 6. Copying Video

Before continuing please be sure to have reviewed the preceding chapters. You are now ready to copy an image or video from the DVR. This chapter will show you how to copy a still image or movie from the recorder.

- Insert the USB pocket driver into the USB slot on the front panel of the DVR to copy.

**USB slot:**

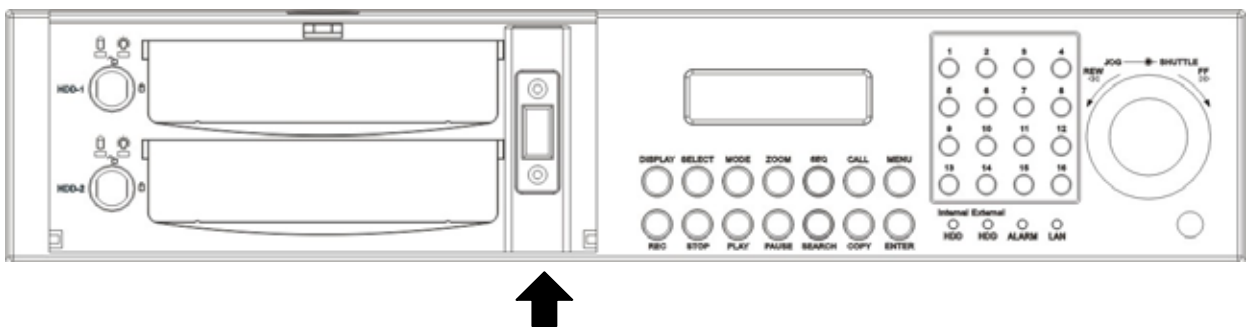

- Digital Video Recorder allows users to select the camera for copying image (video) to movie file or copying EDR Viewer, which is the image (video) player. The camera title will be displaying at the top of the screen.



**COPY**

Press **COPY** key and then the copy menu appears.

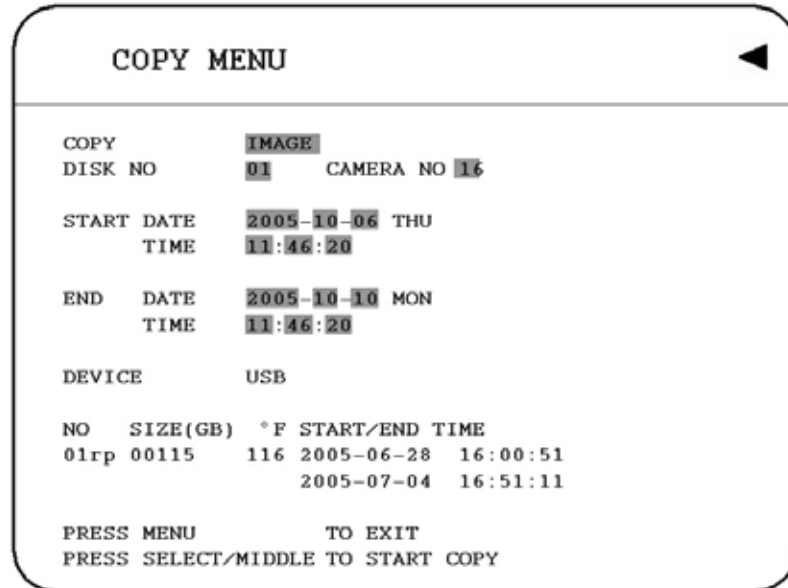

Diagram 6.1

In the **COPY MENU**, we define:

**COPY:** Select **Image (video)** for copying images to movie file.

Select **Viewer** for copying EDR viewer player.

**DISK NO:** Disk number. It is fixed as “01” in this series.

**CAMERA NO:** Camera channel number. You can select the video of camera you would like to copy.

**START DATE & TIME:** The start time of video you want to copy.

**END DATE & TIME:** The end time of video you want to copy.

**DEVICE:** The media you want to store the file. The available device for this model is USB.

Press **SELECT** or tilt wheel of the mouse to copy after setting up everything.

1. During playing back, press **COPY** button. (You will have a default bookmark spanning 5 minutes)
2. Now Stop playback by pressing the **STOP** button and it will bookmark the starting copy point and end copy point. For example, Start copy point will be 10-10-2005 10:00:00 and end copy point will be 10-10-2005 10:05:00. Press **COPY** button to enter the copy menu. In the Copy menu choose image under the copy option. Then, press **SELECT** button to

copy, you will see the **START TIME** has been changed to the “Bookmark time”. The end time is preset to 5 minutes later. You can change it to another value if desired.

## ***6.1 Viewing a Copied File***

- First Step is to download the viewer from your DVR. Insert a USB memory card into the DVR’s appropriate slot. Press **COPY** button to enter the copy menu. In the Copy menu chose viewer under the copy option. Then, press **SELECT** button to copy the viewer to the USB.
- To play the video or image you have stored on the USB memory card is to take the USB memory card and into the USB port of your computer.
- Open up My computer in windows and you will notice a new drive has been added to the computer. This is the USB memory card. To view the files simply click on the drive to open it and you will see the files you archived as well as the viewer you just downloaded.
- Open the DVRViewer.exe for loading the archived EDR MPEG Files (.arv)

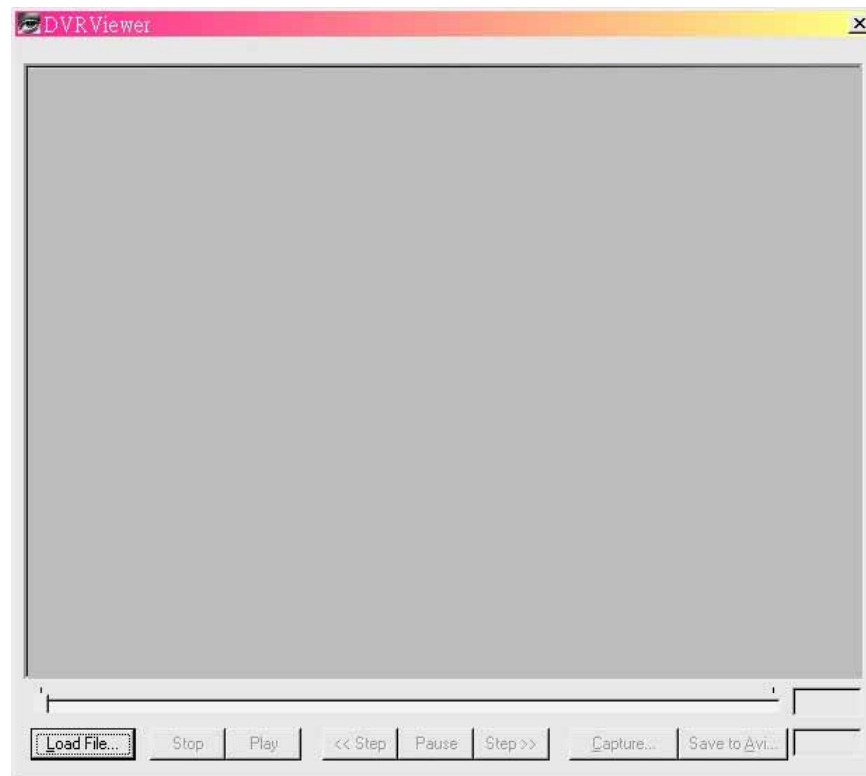



*Note: If you are unable to play “AVI” file downloaded from “DVRViewer”, your PC is required to install “CODEC”, please go to the following URL:  
<http://www.divx.com/divx/play/download/index.php> for downloading DivXPlay.exe. This will enable you to play “AVI” file successfully.*

## 7. Call Overview

This chapter will try to give you details on how to setup the **CALL MENU** on the DVR. Press the **CALL** key and the **CALL MENU** will pop up as below.

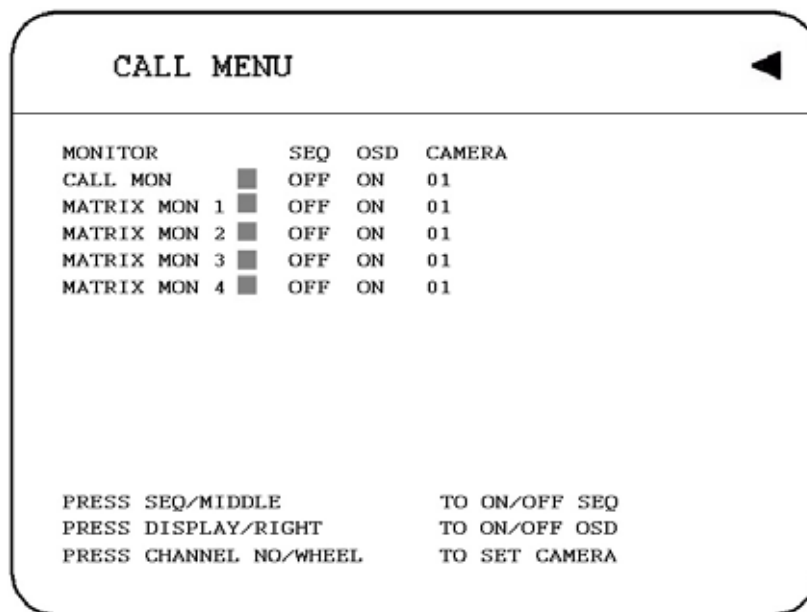

Diagram 7.1

In **CALL MENU**, we define:

- (1) **SEQ:** Sequence display on the call/Matrix monitor. Press **SEQ** to switch “ON” or “OFF” of the sequence status.
- (2) **OSD:** Channel name display on the call/Matrix monitor. Press **DISPLAY** to switch “ON” or “OFF” of the **OSD** status.
- (3) **CAMERA:** The display camera in the call/Matrix monitor. Press **Channel NO** to set display camera.

**(4) CALL MON/MATRIX 1~4:** Display the call monitor and Matrix 1~4 monitors. Press **ENTER** button to move between monitors which will enable you to make selection of **SEQ, OSD** and **CAMERA**.

## 8. Screen Display Setting & Mode

In a full screen display, press **SELECT** key to pop up the display adjustment window as below:

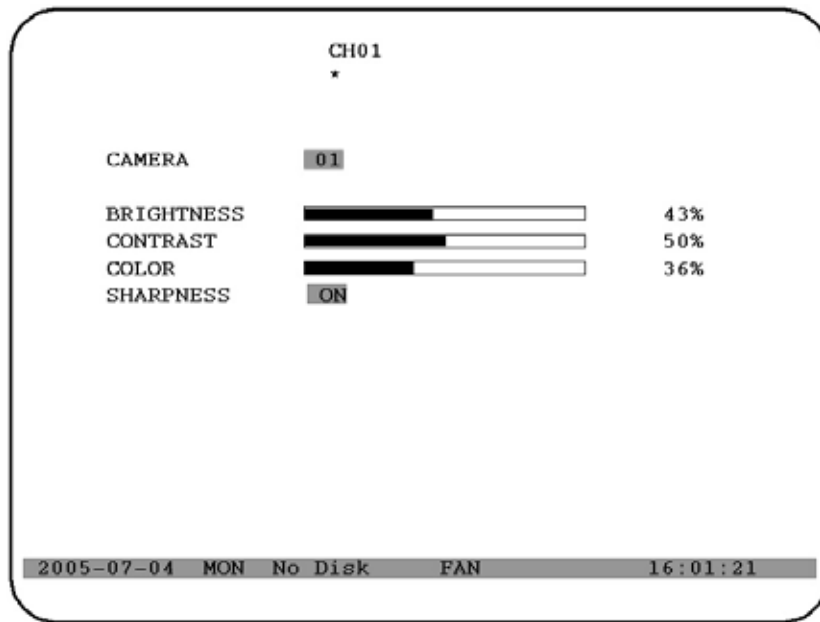

Diagram 8.1

In the screen display setting menu, we define:

- (1) **CAMERA:** The display setting of the current camera.
- (2) **BRIGHTNESS:** The bright percentage of the current camera; from 0% to 100%.
- (3) **CONTRAST:** The contrast percentage of the current camera; from 0% to 100%.
- (4) **COLOR:** The color percentage of the current camera; from 0% to 100%.

(5) **SHARPNESS:**

By turning **SHARPNESS ON**, the image will become sharper and clearer in live mode. This option is suitable for indoor use.

When turning **SHARPNESS OFF**, the image becomes blurred in an indoor environment. However, this option is suitable for outdoor use. If image flickers under a bright, outdoor environment, then the image can become mild by turning **SHARPNESS OFF**.

The selected item will show in red color bar. Use **Jog** to increase or decrease the value. Press **ENTER** to confirm the setting value and move to next item. After finished setting, press **SELECT** or **MENU** key to save and exit the dialog. Total of 16 channels are adjustable.

Pressing **ZOOM** button from front panel will enable you to do screen adjustment. Dial the **Jog** to move leftward and rightward.

## 8.1 Mode Button

Press **MODE** to switch 4, 7, 9, 10, 13, 16 and PIP (picture in picture) displays for Live and Playback mode.

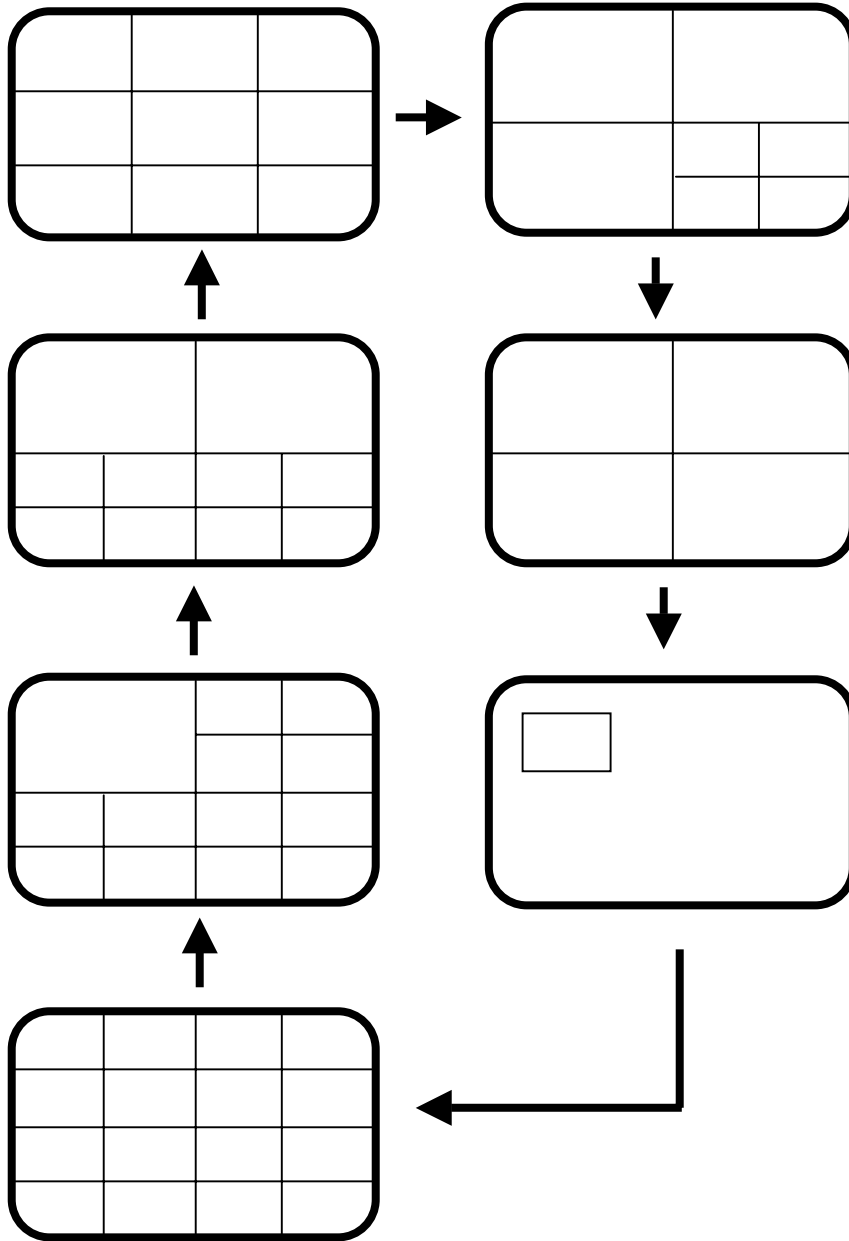

## 9. Upgrade Firmware

This chapter will try to give you a detailed instruction on how to upgrade the DVR. This will be helpful in completing the upgrading process.

- Please go to <ftp://208.50.31.200> and go to DVR Firmware upgrade folder “**Product Firmware Upgrades**”. Then click on the folder that represents you’re the model number of your DVR.
- Copy the .ETW to your USB memory from your computer
- Insert the USB in to the USB slot on the front panel of the DVR. When inserting the USB, make sure the direction of insertion is correct.
- If you are in Record mode hit the stop button to stop recording.
- If the menu pops up when you press the stop button. This usually means you have either the DVR is in Timer record or Motion record. Log into the DVR menu by pressing the Menu button. Go to Either Timer Setting Menu or Motion Record Setting menu and turn them off.
- Once you have stopped any type of recording on the DVR you are ready to upgrade.
- Press the menu button and use the Jog Dial to go to “System” menu.
- Using the enter button to navigate in the menu. Highlight “System Upgrade” turn NO to YES (use jog wheel to select).
- Highlight “YES” again and press “Select” (use jog wheel to select).
- Next to System Upgrade you will notice it say "1/3"
- Once you have read “success” log out of the menu by pressing the menu button twice. Then turn the DVR power off and turn it back on.

## 10. Networking Overview

This chapter will try to give you a detailed instruction on how to network the DVR. Before we begin the process of networking your digital recorder we should have a working knowledge of what a network is and how it works. This will be a helpful in completing the networking process.

### 10.1 Introduction to TCP/IP

TCP/IP is the suite of protocols used by the Internet and most LANs (Local Area Networks) throughout the world. In TCP/IP, every host (computer or other communications device) that is connected to the network has a unique IP address. By doing this you are giving your device a unique address similar to the address of your house. An IP address is composed of four octets (numbers in the range of 0 to 255) separated by decimal points. The IP address is used to uniquely identify a host or computer on the LAN. For example, a computer with the hostname Workstation could have an IP address of 192.168.1.127.

You should avoid giving two or more computers the same IP address by using the range of IP addresses that are reserved for private, local area networks; this range of IP addresses usually begins with the octets 192.168. The first three octets of an IP address should be the same for all computers in the local area network. For example, if a total of 253 computers exist in a single LAN, the IP addresses could be assigned starting with 192.168.1.*x*, where *x* represents a number in the range of 2 to 254.

### 10.2 Subnet Masks

Each host in a LAN has a subnet mask. The *subnet mask* is an octet that uses the number 255 to represent the network address portion of the IP address and a zero to identify the host portion of the address. For example, the subnet mask 255.255.255.0 is used by each host to determine which LAN or class it belongs to. The zero at the end of the subnet mask represents a unique host within that network. Basically the subnet mask represents the city you live in for your home address, but in this case you are stating the network you belong to.



## 10.3 Gateway Address

Each host in a LAN has a gateway. A gateway address is composed of four octets (numbers in the range of 0 to 255) separated by decimal points. The gateway address is used to uniquely identify a host or computer on the LAN which assigns the IP addresses to your network. For example, a Linksys router has an IP address of 192.168.1.1. If you were using this type of router within your LAN, then your gateway would be the IP address of the Linksys router. The reason this would be your gateway is because the Linksys is assigning the IP addresses for your network therefore the Linksys would be the gateway to your network. This is similar to the zip code of your address.

## 10.4 Virtual Ports

A **port number** represents an endpoint or "channel" for network communications. Port numbers allow different applications on the same computer to utilize network resources without interfering with each other. Port numbers most commonly appear in network programming, particularly socket programming. Sometimes, though, port numbers are made visible to the casual user. For example, some Web sites a person visits on the Internet use a URL like the following:

In this example, the number 8100 refers to the port number used by the Web browser to connect to the Web server. Normally, a Web site uses port number 80 and this number need not be included with the URL (although it can be). In IP networking, port numbers can theoretically range from 0 to 65535. Most popular network applications, though, use port numbers at the low end of the range (such as 80 for HTTP). This could be similar to the front door of your house. Without the door to the house being open you could not enter it. This is the same case with ports on a network. If the ports for a specific IP address are not open then you could not gain access to that IP address or what it is addressing.

*Note: The term port also refers to several other aspects of network technology. A port can refer to a physical connection point for peripheral devices such as serial, parallel, and USB ports. The term port also refers to certain Ethernet connection points, such as those on a hub, switch, or router.*

## 10.5 Pre-Installation

Before we begin with the installation we must ask ourselves a few questions in order to figure out where to begin with networking our DVR's.

Do you have Hi-speed Internet? \_\_\_\_\_

There are many types of high speed Internet available. Three commonly used ones are T1, Cable, and DSL (in order of speed).

- ***Note: It is suggests having a minimum upload speed of 256KBps. This can be addressed by the Internet Service Provider.***

Who is your Internet provider? \_\_\_\_\_

- Please confirm that your internet service provider that our upload speed is at least 256KBps.

What type of modem/router do you have? \_\_\_\_\_  
Modem/router model name/ #

The modem/router was either installed by your Internet service provider or purchased by you to establish a connection to the Internet. A router is installed to allow multiple computers to access the Internet through the same external IP address. It in turn assigns different internal IP addresses to local computers for this specific purpose.

Do you have a static IP address? \_\_\_\_\_

A Static IP address means you use the same IP address every time you log on to the Internet. With a static IP address, other Internet users always know the identity of your computer and can easily connect with it. That way, you can host a website, email server, or other type of server connection. It is suggested to use a static IP address. If your Internet provider does not offer a static IP address you have the option to use a dynamic IP address. This will be explained in more detail later on in the chapter.

Do you have a dynamic IP address? \_\_\_\_\_

A Dynamic IP address means your IP address changes each time you make a connection to the Internet. We recommend asking your Internet service provider for a Static IP address. If this is not a possibility, you may purchase a router (we suggest a Linksys or D-link router) which supports DDNS. DDNS is a Dynamic Domain Name Server, a service that provides a central (public) database where DNS information can be stored and retrieved. It allows those using a dynamic IP address to be registered centrally so users can connect to it by name.

What type of DVR are you installing? \_\_\_\_\_

EDR series: EDR 410, 810, 920, 1620, 1640, or 1680

EDSR series: EDSR 110, 400H, 400M, 400, 900, or 1600

## ***10.6 What Type of Network Connection do you have ?***

DVR can operate using three distinct types of networking connections.

1. **Simple One to One Connection:** A simple one to one connection is the most simple network connection. Basically it is a connection between a Computer and Another Computer or in this case a DVR using a cross-over cable.
2. **Direct High Speed Modem Connection:** A direct high speed modem connection is a network connection from the modem directly to a computer or in this case the DVR.
3. **Router or LAN Connection –** A local area network connection either requires a router or a pre-existing LAN connection. Typically this type of connection is the most commonly used application. A router allows multiple computers and DVR's to access each other as well as the Internet. It assigns different internal IP addresses to the computers.

## 10.7 Simple One to One Connection

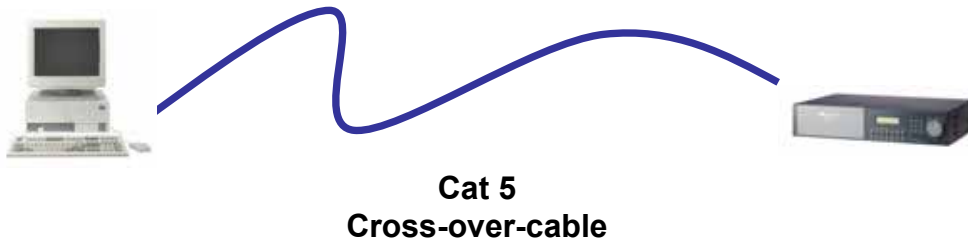

### Crossover Ethernet Cable Pin outs:

The Diagram below shows the pin configurations for a cross over cable.

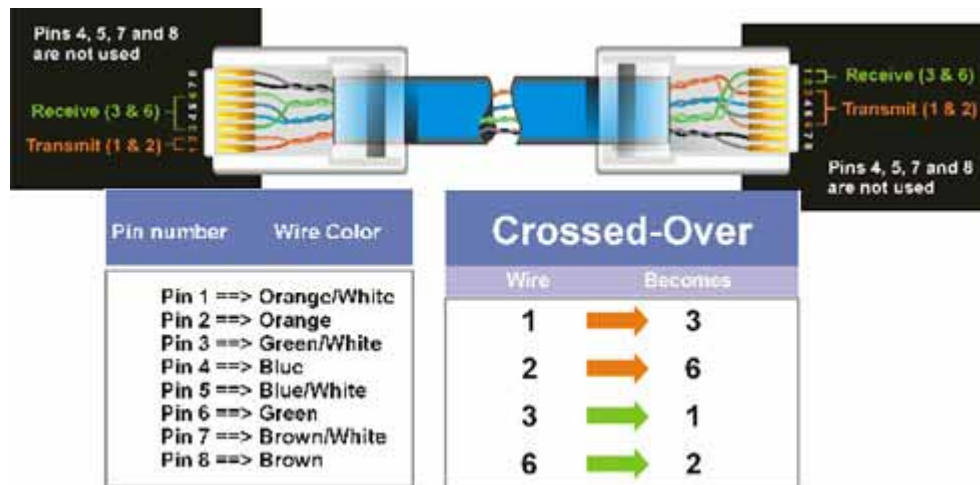
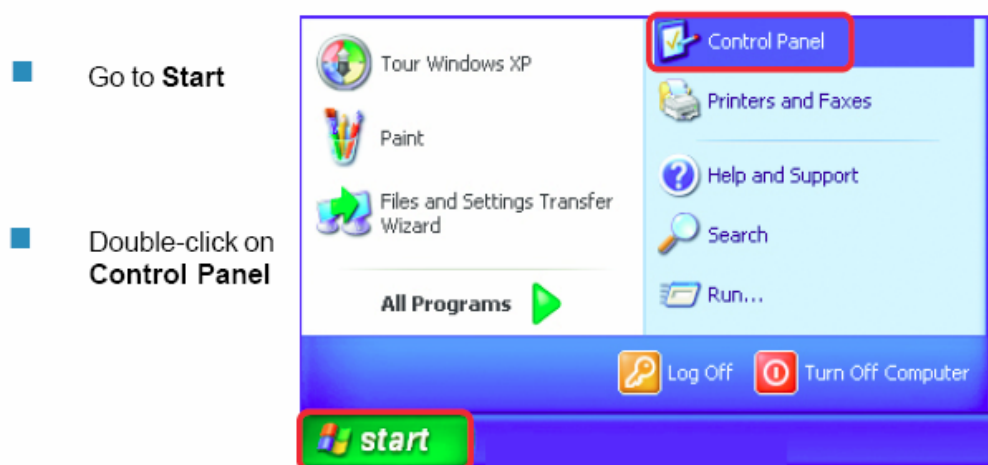

Diagram 10.1

### Connection Procedure:

- The First step is to purchase or make a cross over cable. We recommend purchasing one if you have never made a cross over cable. Please remember you can not use a straight through network cable for this application
- Once you have a cross over cable plug one end into the LAN port on the back of the recorder and the other into the network card on the back of the computer.
- Now Log into the DVR menu and using the jog dial from the previous chapter go to the Network Setting Menu. (Please see **Network Setting Menu** for more instructions)
- Assign an IP address of 192.168.001.003 to the DVR, a Subnet mask of 255.255.255.000, and a default gateway of 192.168.001.001.

- The next step is to get the computer onto the same network to do this you will need administrator access to your windows machine.
- To assign a static IP address in windows 2000/XP.



- Double-click on **Network Connections**

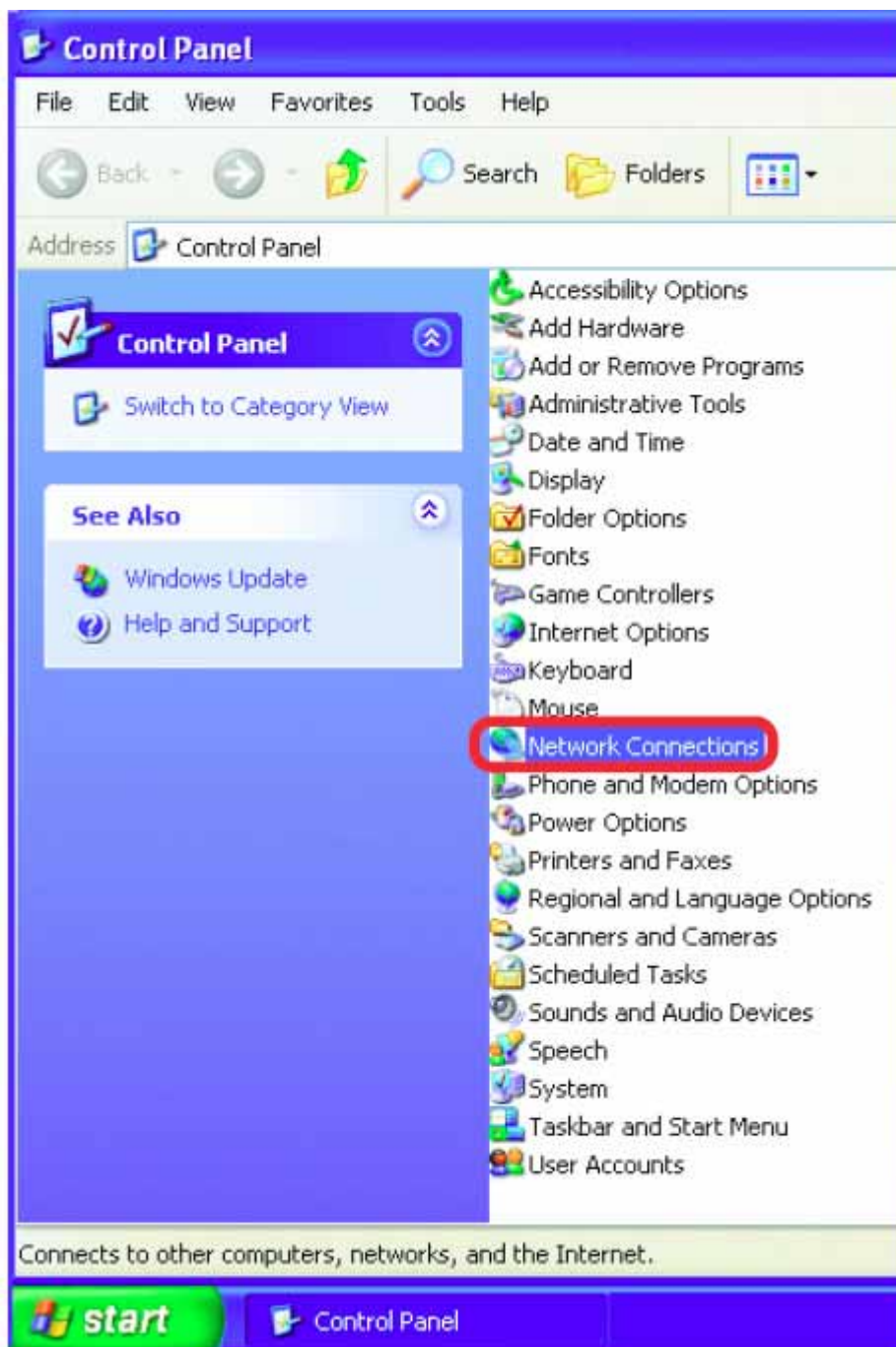

- Right-click on **Local Area Connections**

- Double-click on **Properties**

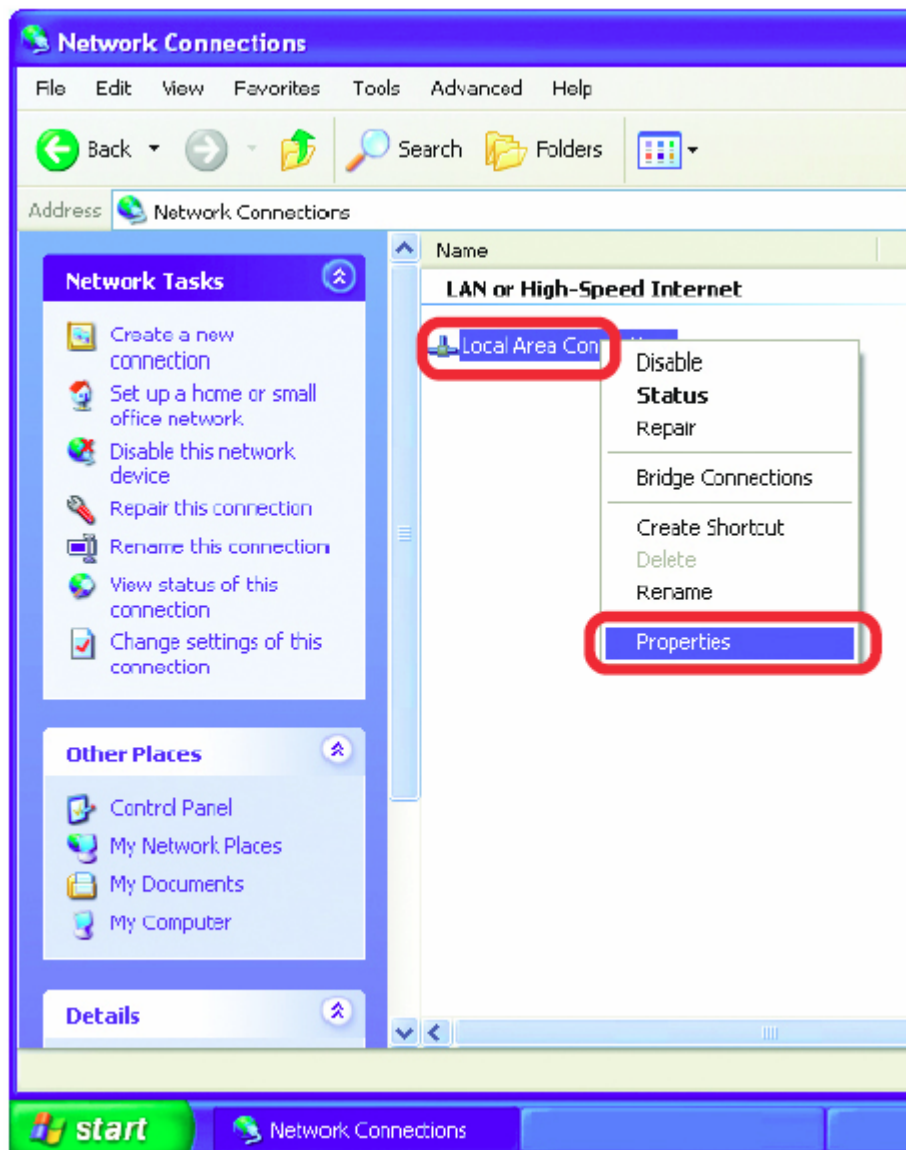

- Click on **Internet Protocol (TCP/IP)**
- Click **Properties**

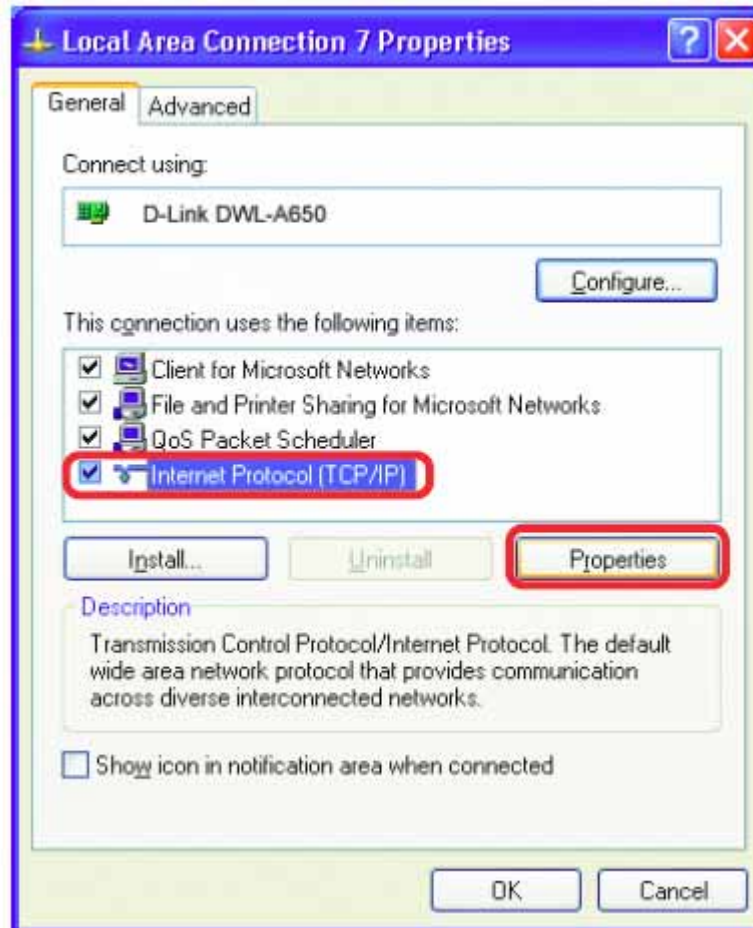



- Input your **IP address and subnet mask.** (The IP Addresses on your network must be within the same range.

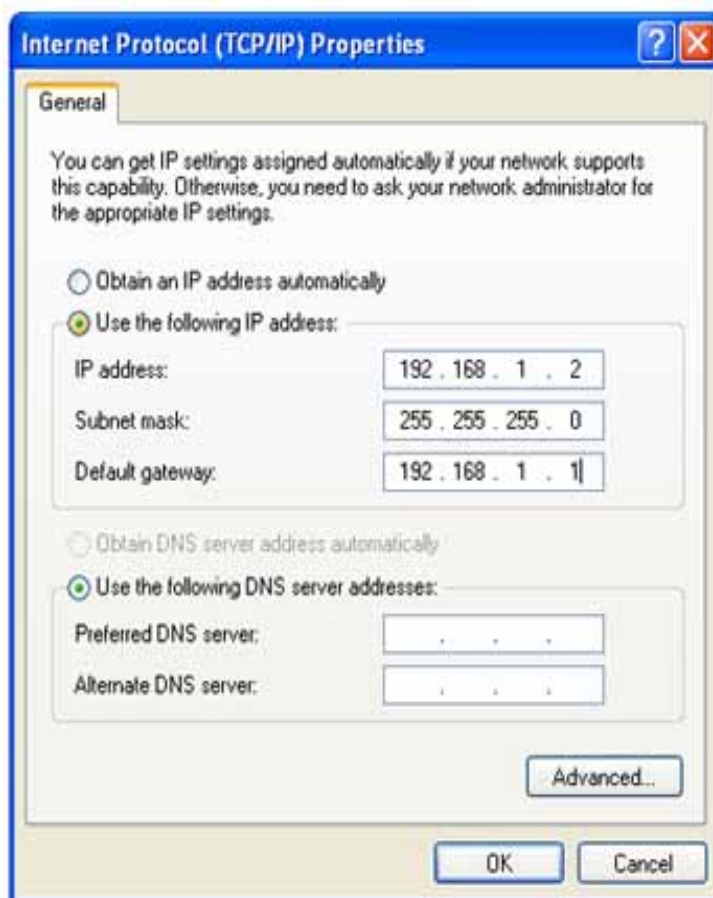

- Once you have reached this point click ok and restart both the computer and the digital recorder.
- To access the DVR from the computer simply open Internet Explorer and in the address bar type:

<http://192.168.1.3>

## 10.8 Direct High Speed Modem Connection

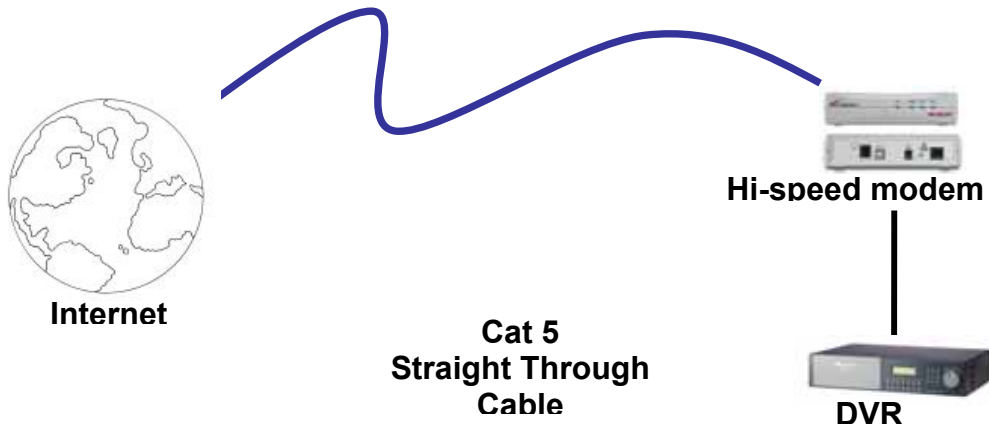

### Straight Through Ethernet Cable Pin outs:

The Diagram below shows the pin configurations for a straight cable.

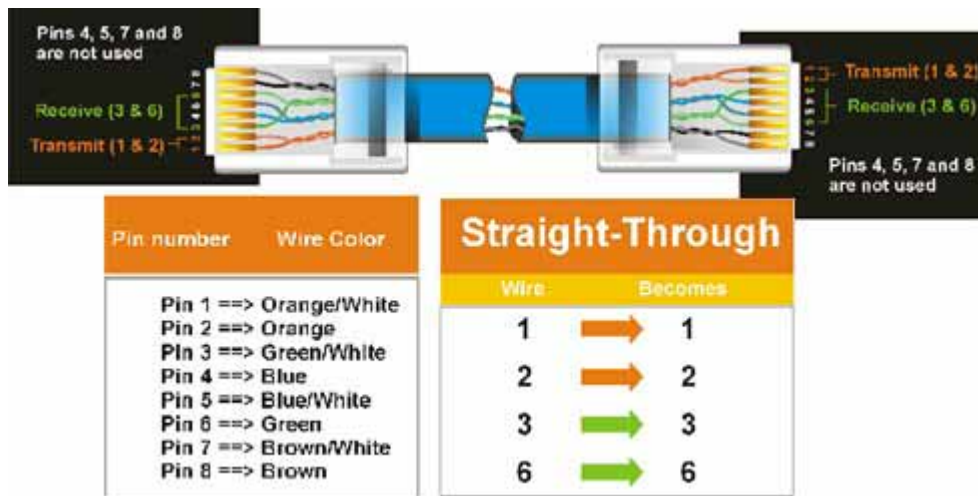

Diagram 10.2

### Connection Procedure:

- The First step is to purchase or make a straight through cable. We recommend purchasing one if you have never made a straight through cable. Please remember you can not use a cross over network cable for this application
- Once you have a straight through cable plug one end into the LAN port on the back of

the recorder and the other into the high speed modem.

- Now Log into the DVR menu and using the jog dial from the previous chapter go to the Network Setting Menu. (See page 28 for more instructions)
- Assign the Static IP address which you obtained from the internet service provider to the DVR, the Subnet mask from the internet service provider to the DVR, and the default gateway of the internet service provider.
- ***Note: If you have a dynamic IP address this type of connection will not work for you. You will need to purchase a router or ask your internet service provider for a static IP address. (Please refer to local area network connection checklist)***
- Once you have reached this point click ok and restart both the computer and the digital recorder.
- To access the DVR from a computer simply open Internet Explorer and in the address bar type:

http:// and the IP address of your internet service provider.

## 10.9 Router or LAN Connection

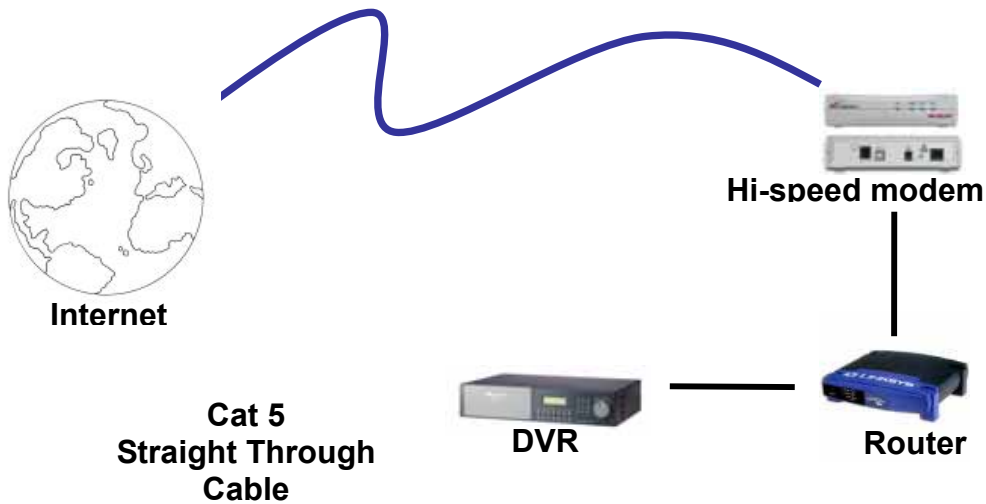

### Straight Through Ethernet Cable Pin outs:

The Diagram below shows the pin configurations for a straight cable.

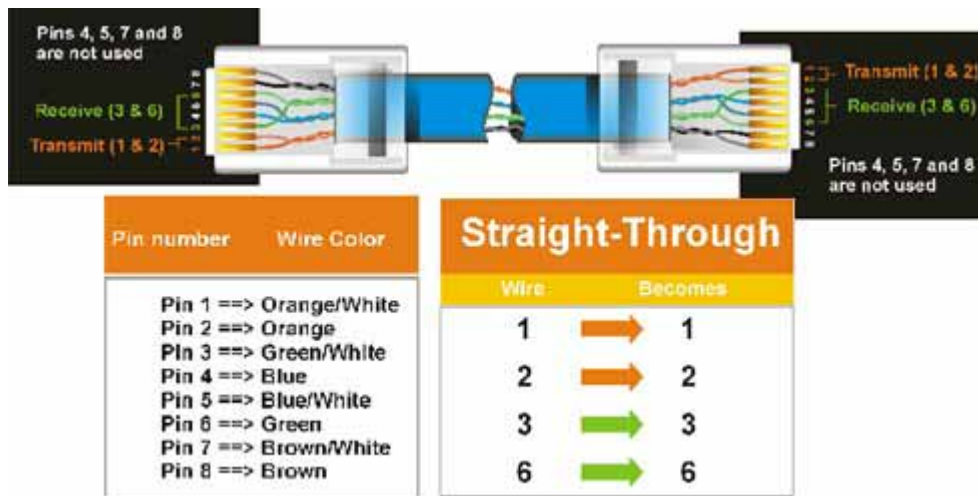

Diagram 10.3

## Connection Procedure:

- The First step is to purchase or make a straight through cable. We recommend purchasing one if you have never made a straight through cable. Please remember you can not use a cross over network cable for this application
- Once you have a straight through cable plug one end into the LAN port on the back of the recorder and the other into the router.
- Now Log into the DVR menu and using the jog dial from the previous chapter go to the Network Setting Menu. (See page 28 for more instructions)
- If you have a Linksys Router:
  - Assign an IP address of 192.168.001.050 to the DVR, a Subnet mask of 255.255.255.000, and a default gateway of 192.168.001.001.

If you have a D-Link Router:

- Assign an IP address of 192.168.000.050 to the DVR, a Subnet mask of 255.255.255.000, and a default gateway of 192.168.000.001.

If you have a pre-existing LAN:

- Go to a Computer on the pre-existing network and do the following:
  - Go to Start, then Run and type cmd and click on OK.
- Then hit enter, type ipconfig and press enter this will give you the information you will need.

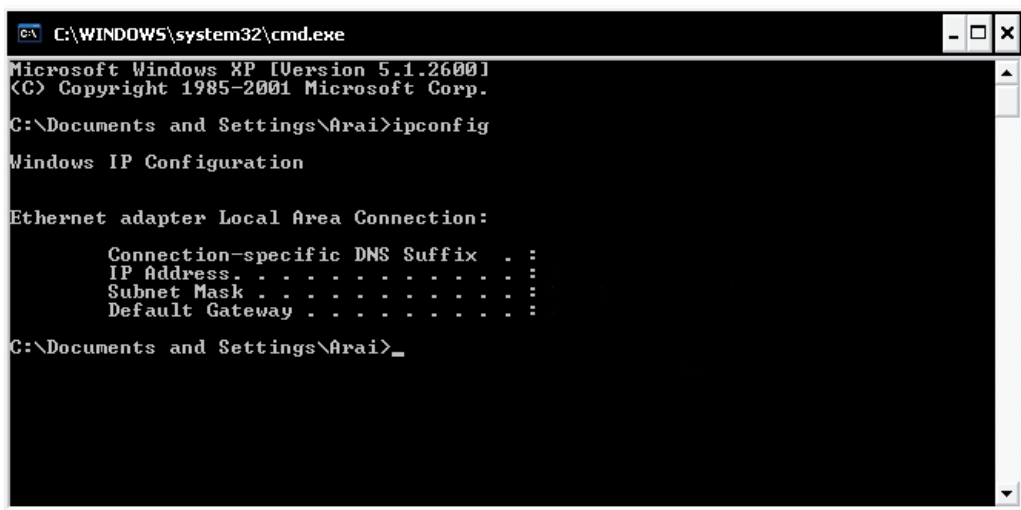

```
C:\WINDOWS\system32\cmd.exe
Microsoft Windows XP [Version 5.1.2600]
(C) Copyright 1985-2001 Microsoft Corp.

C:\Documents and Settings\Arai>ipconfig

Windows IP Configuration

Ethernet adapter Local Area Connection:

    Connection-specific DNS Suffix  . :
    IP Address. . . . .                :
    Subnet Mask . . . . .              :
    Default Gateway . . . . .          :

C:\Documents and Settings\Arai>_
```

- Use the prior step to assign an IP address. For example, if you got the IP address from the computer of 192.168.002.101. Assign the DVR's IP address as 192.168.002.050. Now Copy the subnet mask and default gateway information you got from the prior step off the computer to the DVR.
- ***Note: Make sure the modem is in bridge mode. If your Internet Service Provider is BellSouth you will have a modem/router. BellSouth provides a Westell modem that includes a built-in router. You will need to disable the router functionality.***
- The next step is to open ports within your router. Open virtual ports in the router (Log into the router using a PC)
  - EDR Ports to open: 80, 1600, 37260, 37261, 37262, 37263
  - ***Note: If your Internet service provider blocks port 80 you may use a different port to access the DVR through the DVR's Network Menu Setup.***
  - ***Note: If you wish to have multiple users log into the DVR please open a range for the control and data ports on your router. For example if you would only like 4 clients to connect to the DVR open 1600 and 37260 ~ 37263***
- If you have a Dynamic IP address and have open the ports simply go to Chapter 9 to Configure DDNS.
- Once you have reached this point and you have restarted the digital recorder.
- To access the DVR from a computer simply open Internet Explorer and in the address bar type:
 

http:// and the IP address of your internet service provider.

  - ***Note: If your Internet service provider blocks port 80 you may use a different port to access the DVR through the DVR's Network Menu Setup.***

## 11. Linksys Port Forwarding

This chapter will cover a few simple configurations for the Linksys router. Please understand we do not support this product and will not give tech support on it. If you need Technical support on this router you must call Linksys. This Chapter is to offer some help to the installer and end user nothing more.

To access the Web-based Utility, launch Internet Explorer or Netscape Navigator, and enter the Router's default IP address, **192.168.1.1**, in the *Address* field. Then, press **Enter**. A password request page will appear. (Non-Windows XP users will see a similar screen.) Leave the *User Name* field blank. The first time you open the Web-based Utility, use the default password **admin**. (You can set a new password from the Administration tab's *Management* screen.) Click the **OK** button to continue.



The first screen that appears displays the Setup tab. This allows you to change the Router's general settings. Change these settings as described here and click the **Save Settings** button to

apply your changes or **Cancel Changes** to cancel your changes.

A Division of Cisco Systems, Inc. Firmware Version: 1.04.12

Etherfast® Cable/DSL Router BEFSR41 V3

Applications & Gaming

Setup Security Applications & Gaming Administration Status

Port Range Forwarding Port Triggering UPnP Forwarding DMZ

Port Range Forwarding

Port Range					
Application	Start	End	Protocol	IP Address	Enabled
ABC	80	to 80	Both	192.168.1.150	<input checked="" type="checkbox"/>
DEF	1111	to 1111	Both	192.168.1.150	<input checked="" type="checkbox"/>
GHI	1600	to 1600	Both	192.168.1.150	<input checked="" type="checkbox"/>
	0	to 0	Both	192.168.1.0	<input type="checkbox"/>
	0	to 0	Both	192.168.1.0	<input type="checkbox"/>
	0	to 0	Both	192.168.1.0	<input type="checkbox"/>
	0	to 0	Both	192.168.1.0	<input type="checkbox"/>
	0	to 0	Both	192.168.1.0	<input type="checkbox"/>
	0	to 0	Both	192.168.1.0	<input type="checkbox"/>
	0	to 0	Both	192.168.1.0	<input type="checkbox"/>

Save Settings Cancel Changes Help

CISCO SYSTEMS

The Applications and Gaming Tab allows you to set up public services on your network, such as web servers, ftp servers, e-mail servers, or other specialized Internet applications. (Specialized Internet applications are any applications that use Internet access to perform functions such as videoconferencing or online gaming. Some Internet applications may not require any forwarding.)

To forward a port, enter the information on each line for the criteria required. Descriptions of each criteria are described here.



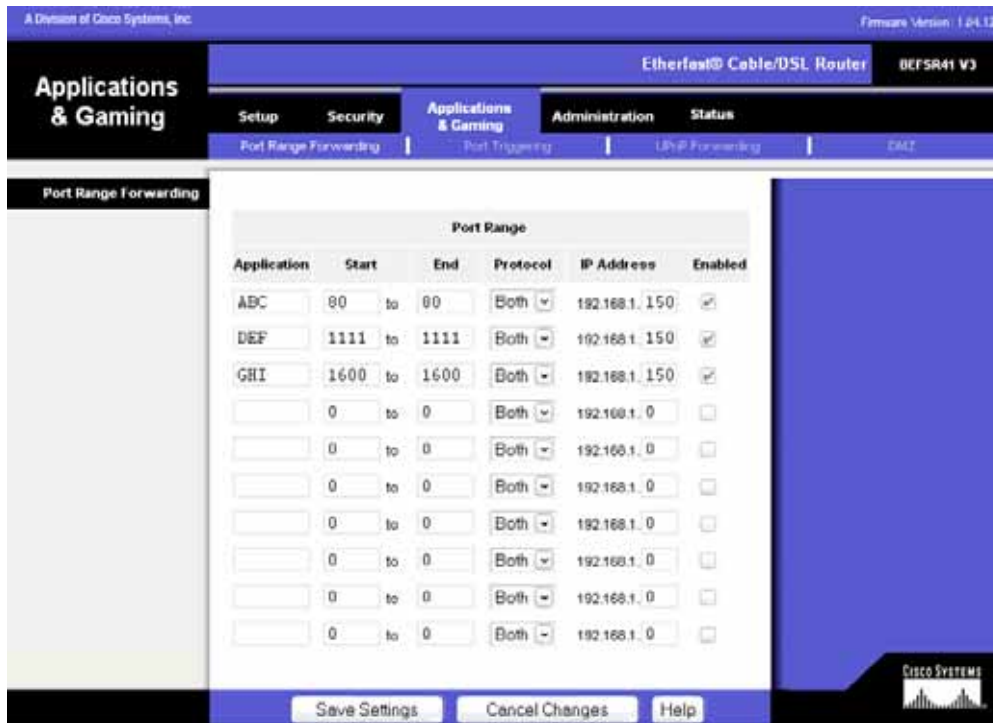

**Application** - In this field, enter the name you wish to give the application. Each name can be up to 12 characters.

**Start/End** - This is the port range. Enter the number that starts the port range under **Start** and the number that ends the range under **End**.

**Protocol** - Enter the protocol used for this application, either **TCP** or **UDP**, or **Both**.

**IP Address** - For each application, enter the IP Address of the PC running the specific application.

**Enable** - Click the **Enable** checkbox to enable port forwarding for the relevant application.

Change these settings as described here and click the **Save Settings** button to apply your changes or **Cancel Changes** to cancel your changes.

Example:

DVR	80 to 80	Both	192.168.1.50	Enable
DVR	1600 to 1600	Both	192.168.1.50	Enable

DVR 37260 to 37260 Both 192.168.1.50 Enable

- *Note: If your Internet service provider blocks port 80 and you are using a different port to access the DVR through the DVR's Network Menu Setup please open those specific ports in this section of the router.*

The following is the address you would type:

http:// IP address of your internet service provider: 8100

## Dynamic DNS

The Router offers a Dynamic Domain Name System (DDNS) feature. DDNS lets you assign a fixed host and domain name to a dynamic Internet IP address. It is useful when you are hosting your own website, FTP server, or other server behind the Router. Before you can use this feature, you need to sign up for DDNS service at [www.dyndns.org](http://www.dyndns.org), DDNS service providers.

**DDNS Service** - From this pull-down menu, enter the DDNS service with which you have membership.

**User Name** - Enter the User Name for your DDNS account.

**Password** - Enter the Password for your DDNS account.

**Host Name** - There is the DDNS URL assigned by the DDNS service.

**Internet IP Address** - This is the Router's current IP Address as seen on the Internet.

**Status** - This displays the status of the DDNS connection.

Change these settings as described here and click the **Save Settings** button to apply your changes or **Cancel Changes** to cancel your changes.

**LINKSYS**  
A Division of Cisco Systems, Inc.

Firmware Version: 1.04.12

**Etherfast® Cable/DSL Router**    BEFSR41 V3

**Setup**

Setup    Security    Applications & Gaming    Administration    Status

Basic Setup    **DDNS**    MAC Address Clone    Advanced Routing

**DDNS**

DynDNS.org

DDNS Service:

User Name:

Password:

Host Name:

Internet IP Address: **129.44.56.193**

Status: **DDNS server is currently closed.**

CISCO SYSTEMS

## 12. D-Link Port Forwarding

This chapter will cover a few simple configurations for the D-Link router. Please understand we do not support this product and will not give tech support on it. If you need Technical support on this router you must call D-Link. This Chapter is to offer some help to the installer and end user nothing more.

Whenever you want to configure your network or the DI-624, you can access the Configuration Menu by opening the web-browser and typing in the IP Address of the DI-624. The DI-624 default IP Address is shown at right:

- Open the web browser
- Type in the **IP Address** of the Router (<http://192.168.0.1>)

*Note: if you have changed the default IP Address assigned to the DI-624, make sure to enter the correct IP Address.*

- Type **admin** in the **User Name** field
- Leave the **Password** blank
- Click **OK**

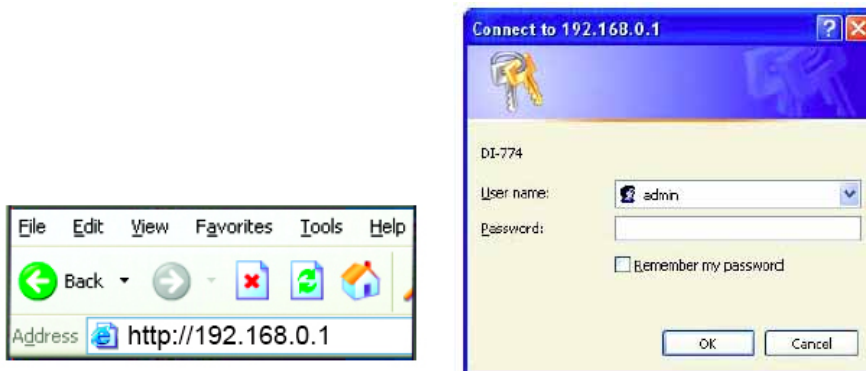

- The next step is to open ports within your router. Go to Virtual Server in the router.

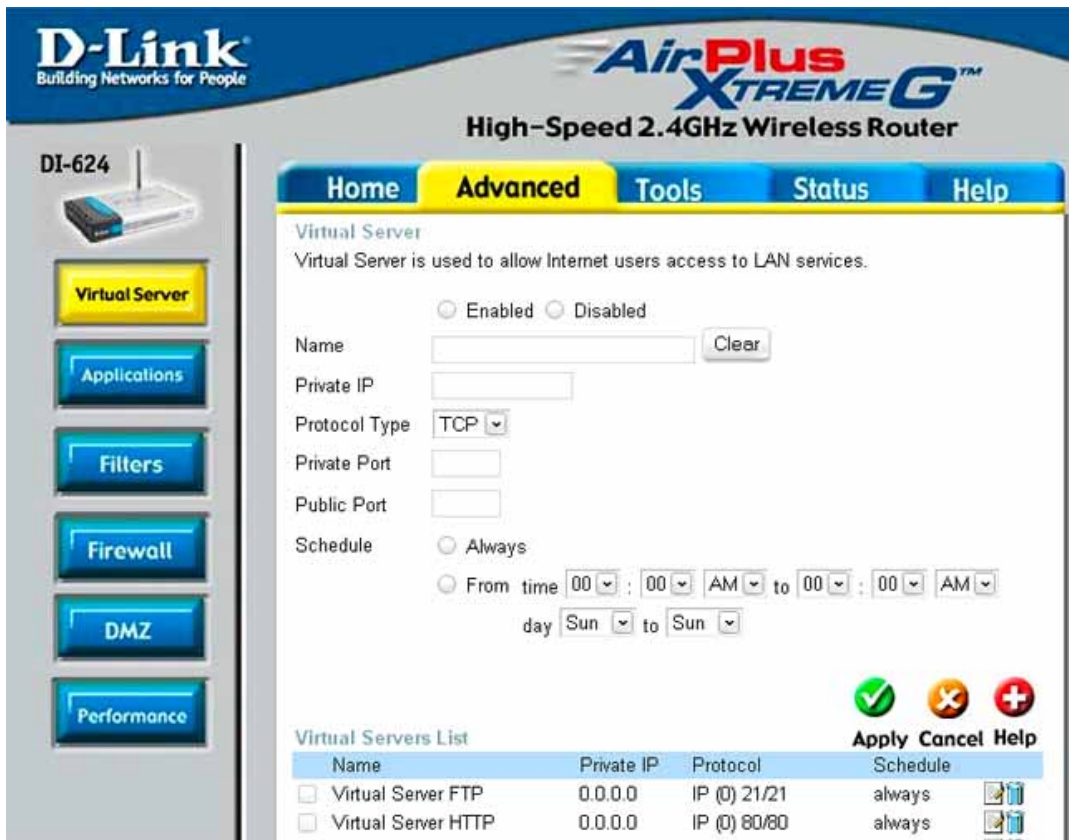

**Example1:**

**Protocol Type** - The protocol used for the virtual service.

**Public Port** - The port number on the WAN (Wide Area Network) side that will be used to access the virtual service.

**Private Port** - The port number of the service used by the Private IP computer.

**Schedule** - The schedule of time when the virtual service will be enabled.

The schedule may be set to **Always**, which will allow the particular service to always be enabled. If it is set to **Time**, select the time frame for the service to be enabled. If the system time is outside of the scheduled time, the service will be disabled.

**Virtual Server** - Select **Enabled** or **Disabled**

**Name** - Enter the name referencing the virtual service

**Private IP** - The server computer in the LAN (Local Area Network) that will be providing the

virtual services. If you have a Web server that you wanted Internet users to access at all times, you would need to enable it. Web (HTTP) server is on LAN (Local Area Network) computer

192.168.0.50 HTTP uses port 80, TCP and UDP.

Name: DVR

Private IP: 192.168.0.50

Protocol Type: Both

Private Port: 80

Public Port: 80

Schedule: always

- The next step is to open ports within your router. Open virtual ports in the router.
  - EDR Ports to open: 80, 1600, 37260, 37261, 37262, 37263
    - *Note: If your Internet service provider blocks port 80 and you are using a different port to access the DVR through the DVR's Network Menu Setup please open those specific ports in this section of the router.*
- If your Internet Service Provider Blocks port 80. Simply do the following:
  - Change the HTTP port from 80 to 8100 in the **NETWORK MENU**.
- To access the DVR from a computer simply open Internet Explorer and in the address bar type:

The following is the address you would type:

http:// IP address of your internet service provider: 8100

## Dynamic DNS

Dynamic Domain Name System is a method of keeping a domain name linked to a changing IP Address. This is a useful feature since many computers do not use a static IP address.

- To setup Dynamic DNS simple go to Tools and the Misc. At the bottom of the screen you will be able to enable DynDNS.
- Once you have enabled it enter the server address of DynDNS.org:

members.dyndns.org

- Then enter the hostname you created with DynDNS.org
- Then enter the username and password you use to log into DynDNS.org

DI-624



Admin

Time

System

Firmware

Misc.

Cable Test

Home

Advanced

Tools

Status

H

#### Ping Test

Ping Test is used to send "Ping" packets to test if a computer is on the Internet.

Host Name or IP  
address

Ping

#### Restart Device

Reboots the DI-624.

Reboot

#### Block WAN Ping

When you "Block WAN Ping", you are causing the public WAN IP address on the DI-624 to not respond to ping commands. Pinging public WAN IP addresses is a common method used by hackers to test whether your WAN IP address is valid.

Discard PING from WAN side  Enabled  Disabled

#### UPNP Settings

Enabled  Disabled

#### Gaming Mode

Enabled  Disabled

#### VPN Pass-Through

Allows VPN connections to work through the DI-624.

PPTP  Enabled  Disabled

IPSec  Enabled  Disabled

#### Dynamic DNS

DDNS  Enabled  Disabled

Server Address

Host Name

Username

Password



## 13. DDNS

This chapter will cover a few simple configurations for setting up DDNS. Please understand we do not support this product and will not give tech support on it. If you need Technical support on DDNS you must call Linksys or D-Link. This Chapter is to offer some help to the installer and end user nothing more.

### 13.1 Creating a DDNS Account

- The first step is to open Internet Explorer and in the address bar type:

<http://www.dyndns.org>

- The next step is to register with dyndns.org by clicking on sign up now.

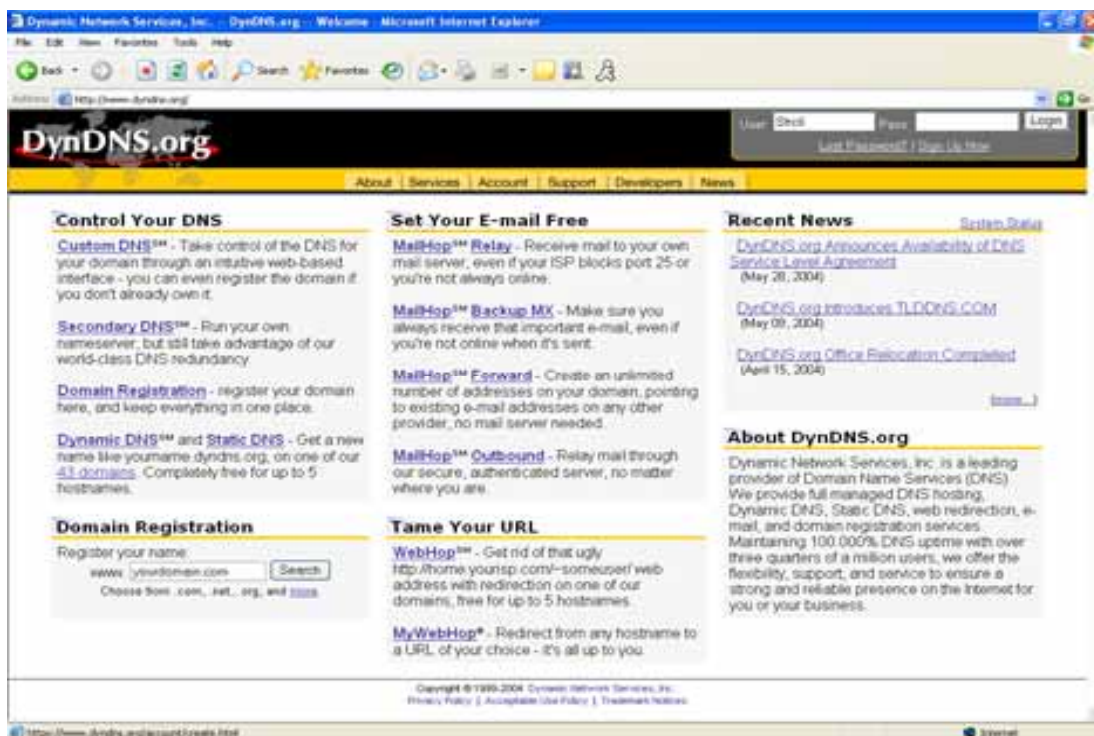

- This is where you file out the information DynDNS requires. You will then receive an email to confirm your account once you confirm you will login into DynDNS.org.

- After you have logged in click on the account tab and then click on Add Host link right next to Dynamic DNS.

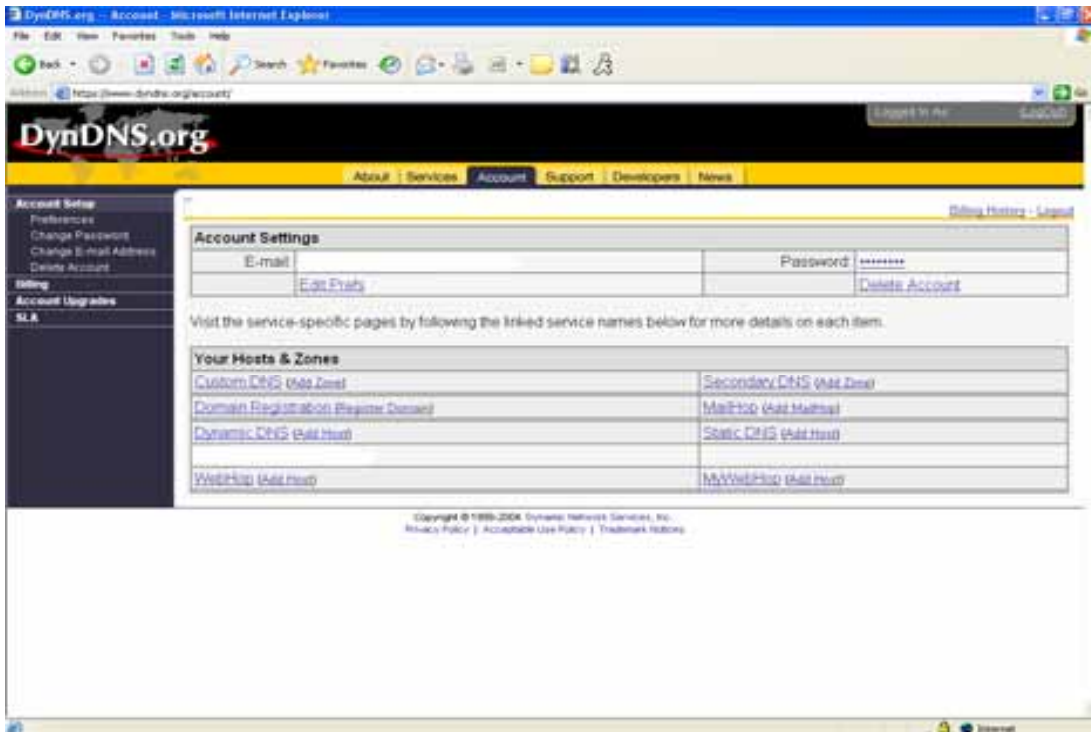

- The next step is to add a host name with an extension.
- The IP address should already be entered for you. All you have to do is click add host and you are done registering DDNS.
- You may refer to the previous two chapters to set up DDNS within your router.

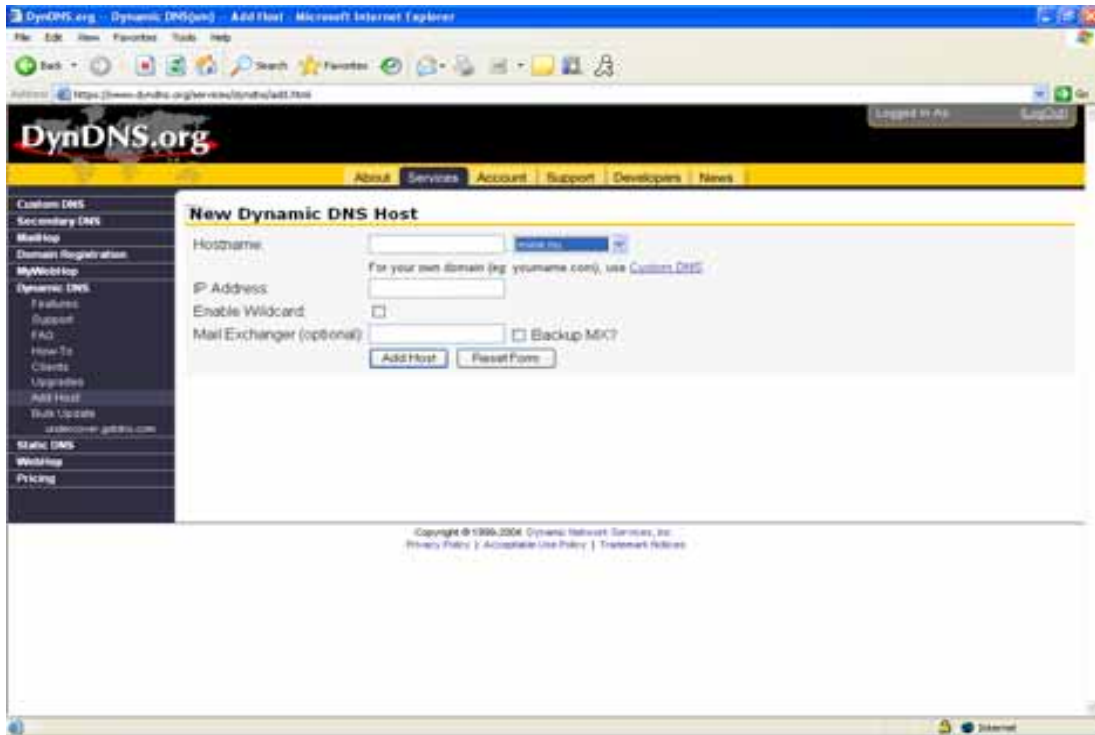

- To access the DVR from a computer simply open Internet Explorer and in the address bar type:

http:// The DDNS you created example everfocu.homeip.net

## 14. Viewing through Internet Explorer

- To access the DVR from a computer simply open Internet Explorer and in the address bar type:

http:// (LAN or IP address of your internet service provider)



- The digital video login page will appear on the screen similar to the one shown above.
- User must enter a user name and password to access the recorder. You can find your user name and password in the Network setting menu of your DVR.
- The Default user name and password are admin and 11111111. (Remote user ID and Password can be found in the Network Menu)
- Then click on the submit button and you will be logged into your recorder.

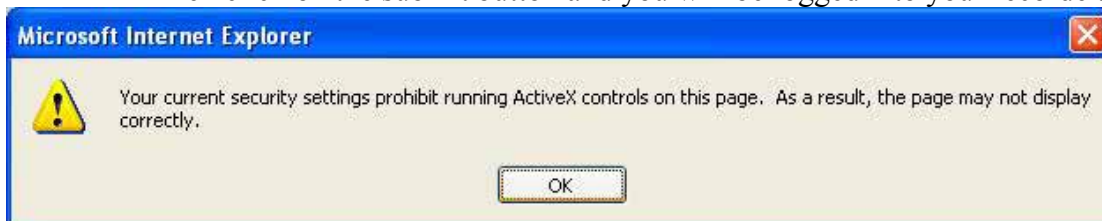

If the above error message pops up when you connect to EDR for viewing from internet, you

should change Internet Option of IE (browser) to enable ActiveX controls.



Select **Tools** -> **Internet Options...**

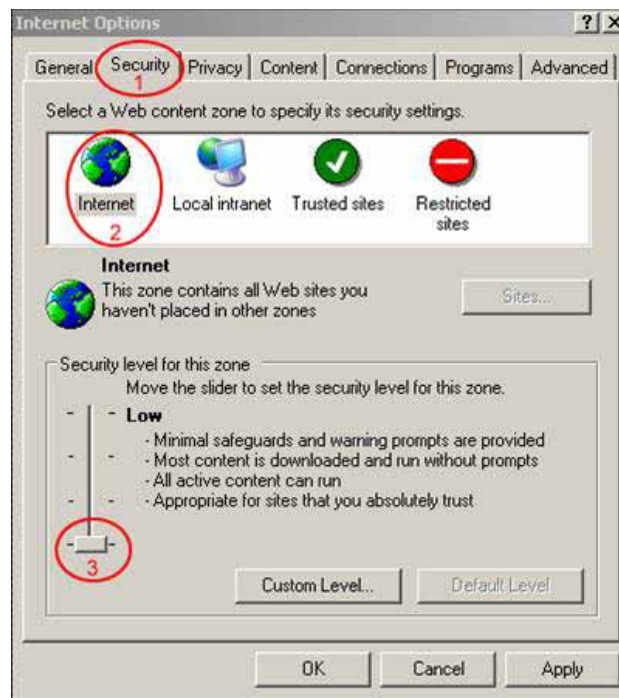

Please refer to the above steps for changing **Security Options** to **Low**.

Main Screen:

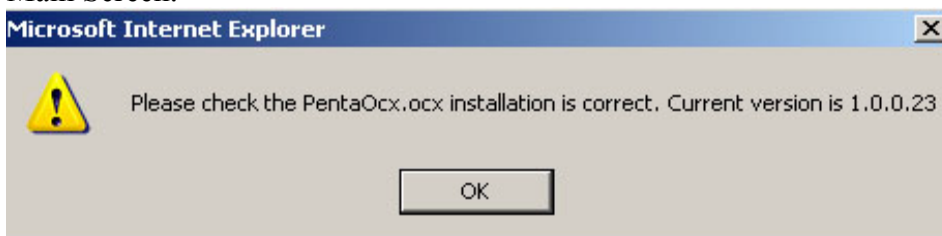

If the above error message pops up when you connect to EDR for viewing from internet, this usually happens if your pentaocx file is outdated or not installed.

To Remedy this problem simply go to Start and Search.



Search Your Computer for the following file pentaocx.

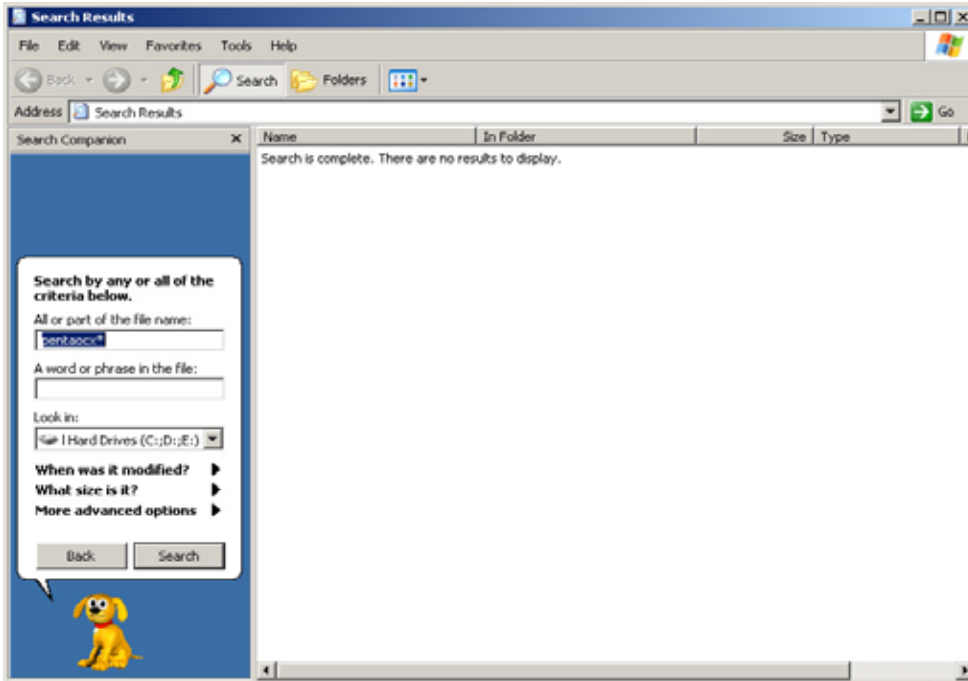

Once you have found the files, delete them.

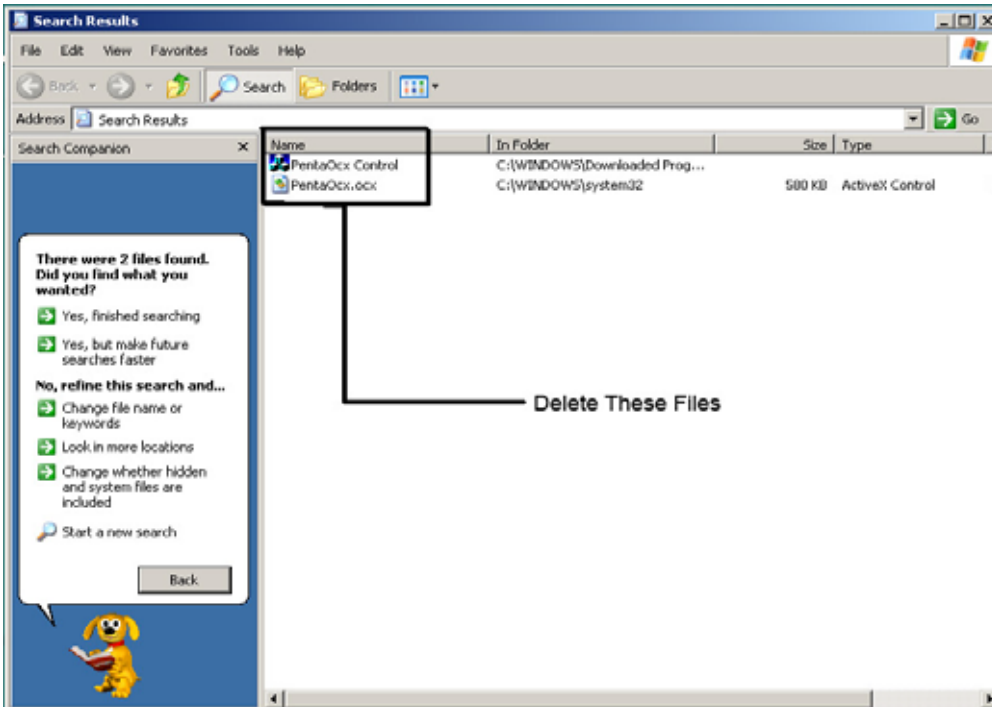

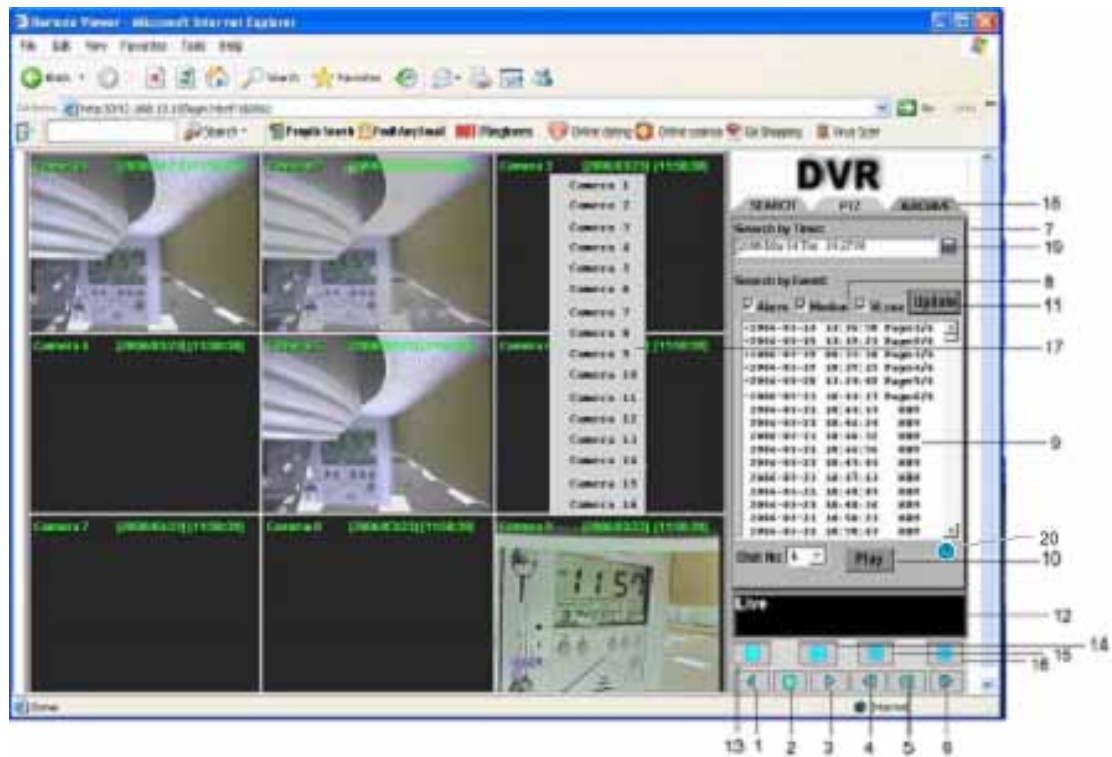







The above diagram is the main screen display.

The icons on the lower corner of the screen are mainly for control and configuration; those on the right corner are for status indication.

If any icon is grayed, it means that the specific function is not accessible in the current mode.

The followings are a brief description for each of the icons.

1.  **REV. PLAY:** Reverse Video Playback.
  2.  **STOP:** Press this key to stop Video Playback.
  3.  **PLAY:** Play back the Video display.
  4.  **STEP FORWARD:** the Video Playback display.
  5.  **PAUSE:** To pause the Video Playback display.
  6.  **STEP BACKWARD:** the Video Playback display.
7. The system allows up to 2 ways to playback video, by **EVENT LIST** and **Time**.



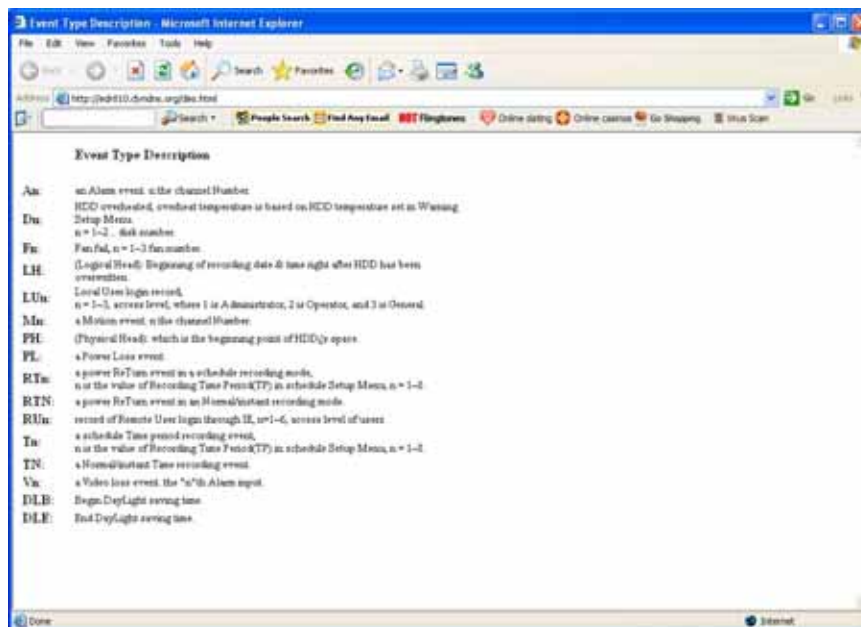

8. Events to be searched: **Alarm, Motion and Vloss.**
9. All available events are shown in the list. Select the desired event and it will be highlighted.
10. Click on “**Play**” to playback selected video event.
11. Press “**Update**” to refresh the event list.
12. Current connection and playback status are shown along with date and time.
13. Full screen view.
14. Quad screen view.
15. Nine split screen view.
16. Sixteen split screen view.
17. A pop-up menu to select camera to view will be shown by right-clicking the mouse.
18. There are 3 main functions of Remote Viewer: **SEARCH, PTZ and ARCHIVE.** **SEARCH** section allows you to search by event or by time. **PTZ** section allows you to do PTZ control. **ARCHIVE** section allows you to archive files or download DVRViewer.
19. **Pick a date** allows you to search by time in a more convenient way.
20. **Event Description:** By clicking on the ? sign, an event description list will show up as follow:

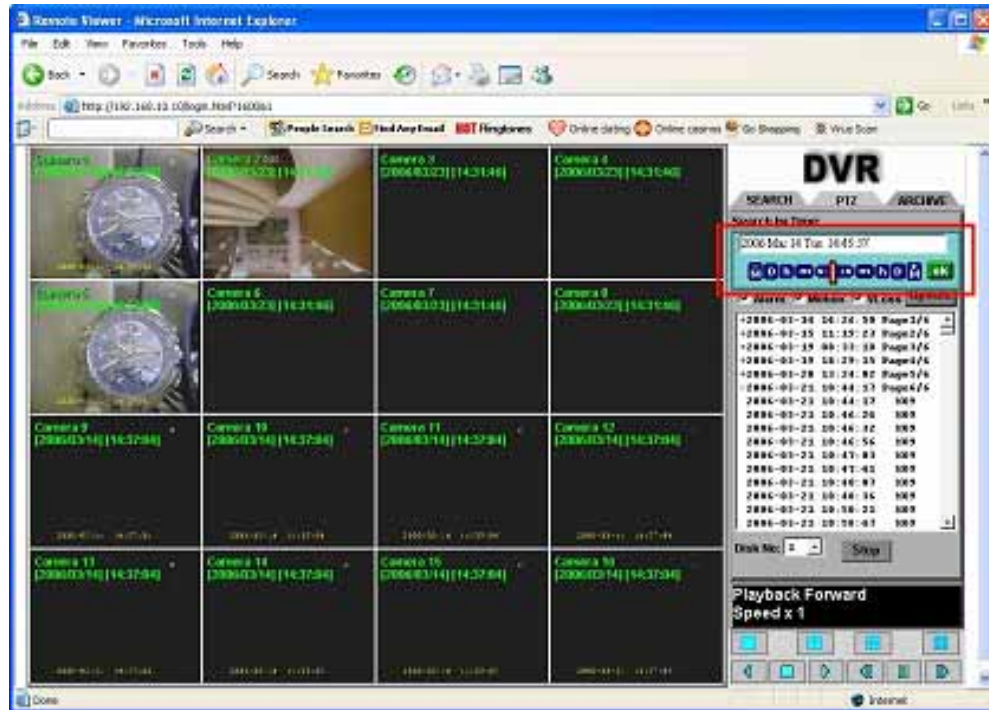

## 14.1 SEARCH

### 14.1.1 Search by Time



There are 3 ways to do search by time. Press  **Pick a date** first.

1. Press the button of **M** for changing Month to be searched, **D** for day, **h** for hour, **m** for minute and **s** for second. The “-” sign at the left-hand side is to decrease the value, whereas the “+” sign at the right-hand side is to increase the value.

2. Move the slide bar between the buttons to change Month, Day, Hour, Minute, and second to be searched. Move the slide bar to the left-hand side for increasing the value, or right-hand side for decreasing the value.

3. Enter Month, Day, Hour, Minute, and second directly in display bar.

Press **OK** to start searching.



## 14.1.2 Search by EVENT

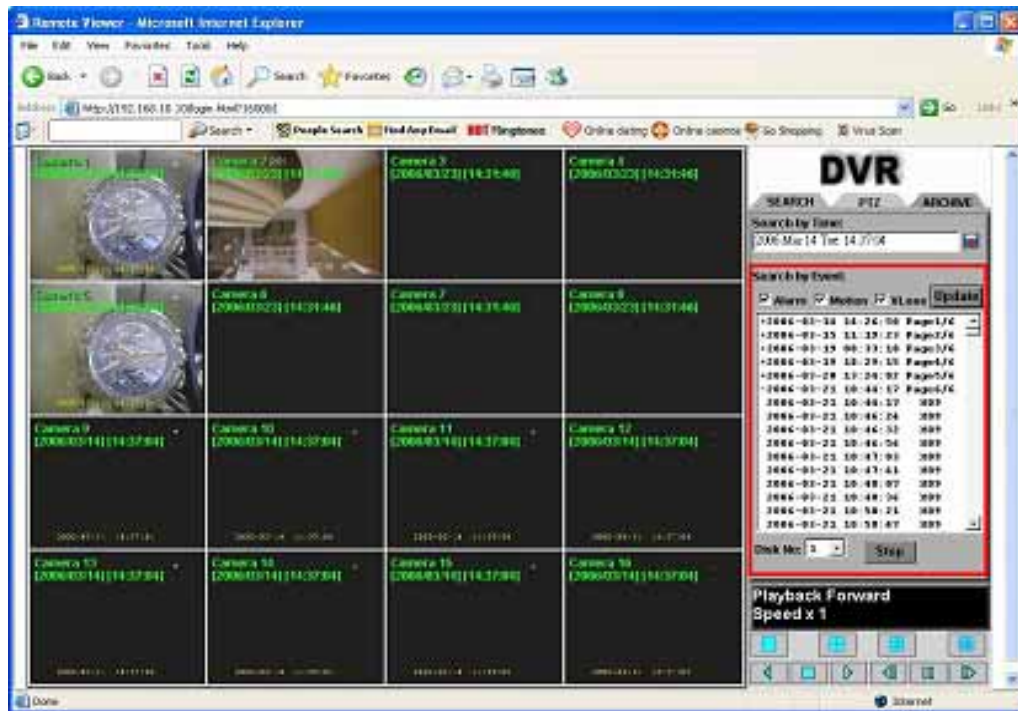

- I. Select Event Type from **Alarm**, **Motion** and **VLoss**.  
*Note: Please keep at least one event type checked.*
- II. Press **Update** button to refresh the event list.
- III. All events of the selected type will be displaying along with Date/Time, event type (represents by a capital letter), camera number (represents by a number), e.g. M02 is the motion event from camera 2.
- IV. When there is a “+” sign in front of the date with page number at the end, it means that you can go to that page for showing the events of that page.
- V. Select the **Disk No.** from which you would like to search events.
- VI. Press **Play** button to playback the selected event.

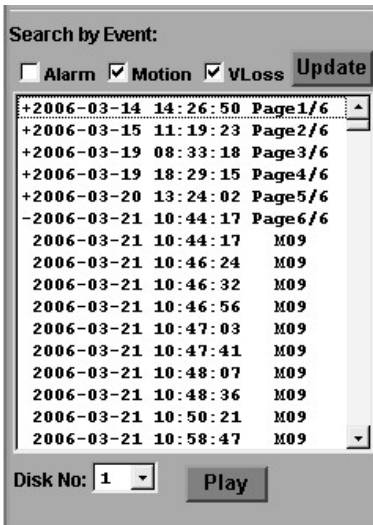

## 14.2 PTZ control

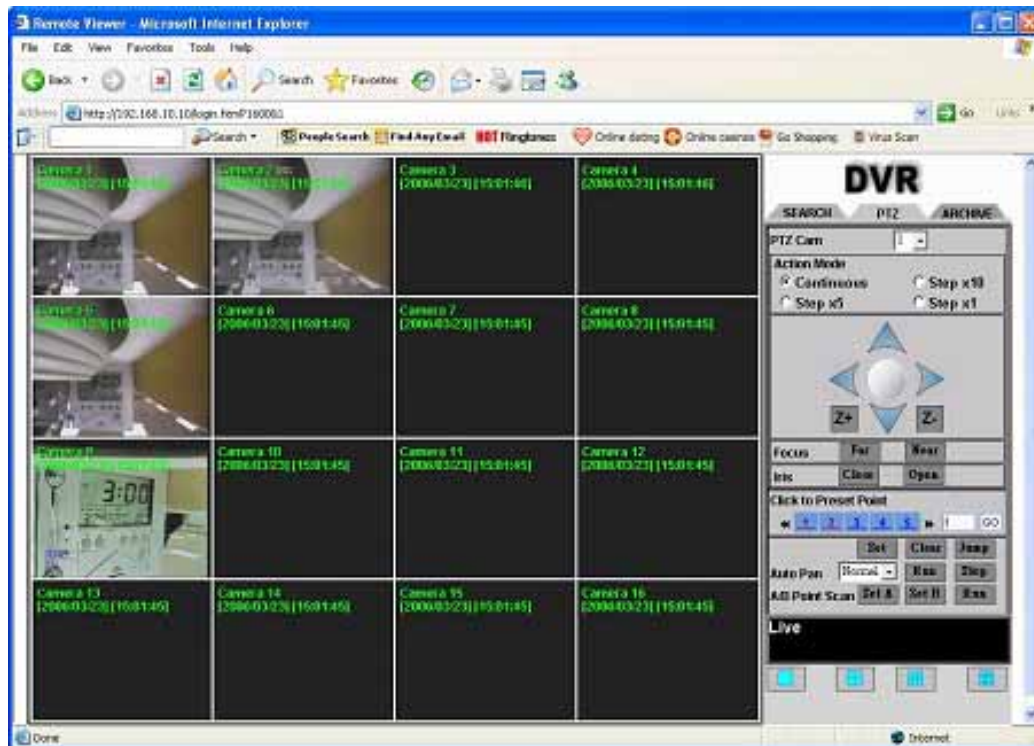

- I. Select the PTZ camera from drop-down menu.
- II. Select **Action Mode**. 4 options are available: **Continuous**, **Step x10**, **Step x5** and **Step x1**.
- III. Use Direction Arrows (up, down, left, right) to move/adjust the focus to your desired direction and angle.
- IV. Press **Z+** for Zooming In or **Z-** for Zooming Out.
- V. In **Focus** option, press **Near** to move the focus closer to the subject. Or you can move the focus farther from the subject by pressing **Far**.
- VI. You can turn on the **Iris** by pressing **Open** or turn it off by pressing **Close**.
- VII. "**Click to Preset Point**" helps you to define the preset point at which you would like to see the subject. Press **Set** for confirmation, **Clear** to exit or **Jump** to jump to a specific point.
- VIII. "**Auto Pan**" is to define the speed of PTZ camera when moving horizontally, please select from **Slower**, **Slow**, **Normal**, **Fast** to **Faster**. Press **Run** for confirmation or **Stop** to exit.

- IX. A/B Point Scan allows you to do tour between 2 points. Move to the first point by using direction arrows and press **SET A**. Then move to the second point by using direction arrows and press **SET B**. Press **RUN** to start A/B Point Scan.

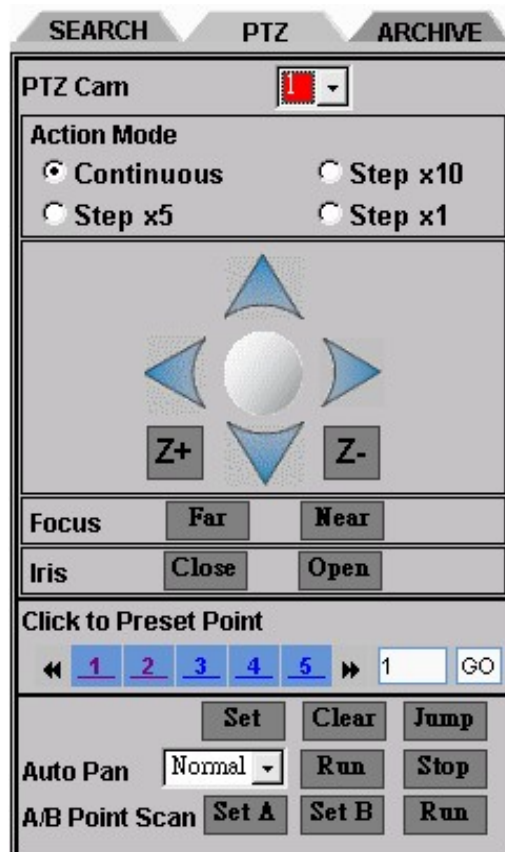

## 14.3 REMOTE ARCHIVE

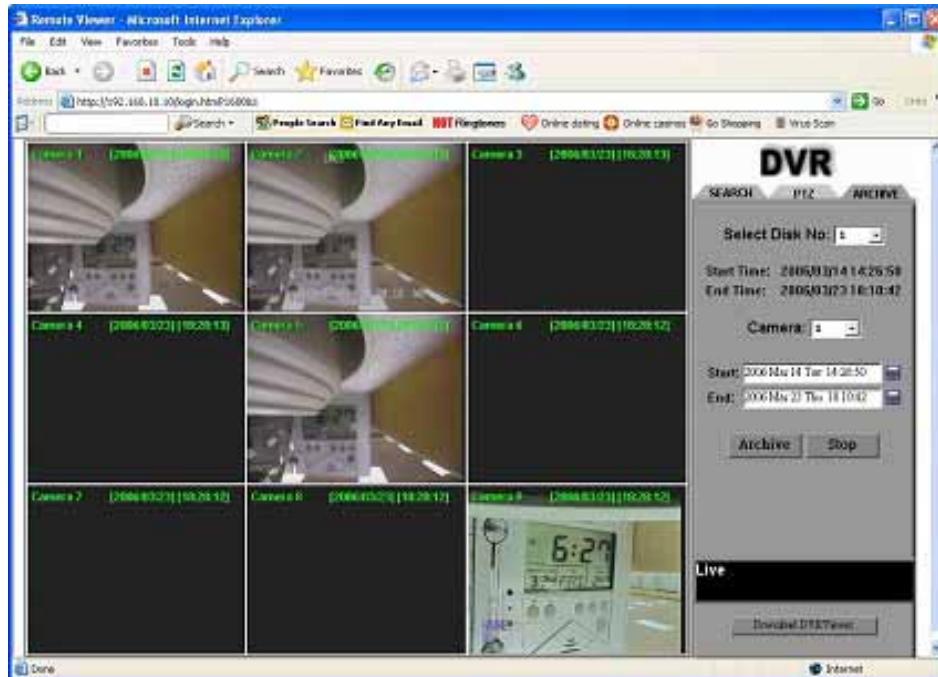

To Archive files:

- I. **Select Disk No.**
- II. **Start Time/End Time** indicates the start and end time of the disk selected
- III. **Camera:** Select the camera that you wish to archive files.
- IV. **Start:** Select the start time to be archived.
- V. **END:** Select the end time to be archived.

There are 3 ways to search either **Start** or **End** time to be archived. Press  first.



1. Press on the button of **M** for changing Month to be searched, **D** for day, **h** for hour, **m** for minute and **s** for second. The “-“ sign at the left-hand side is to decrease the value, whereas the “+” sign at the right-hand side is to increase the value. Press **OK**
  2. Move the slide bar between the buttons to change Month, Day, Hour, Minute, and second to be searched. Move the slide bar to the left-hand side for increasing the value, or right-hand side for decreasing the value.
  3. Enter Month, Day, Hour, Minute, and second directly in display bar.
  4. Press **OK** to start searching.
- VI. Press **ARCHIVE** button to start archiving. A “.arv” file will be saved.
- VII. Press **STOP** button if you wish to cancel archiving.

The screenshot shows a software interface with three tabs at the top: SEARCH, PTZ, and ARCHIVE. The ARCHIVE tab is selected. Below the tabs, there are several fields and buttons:

- Select Disk No:** A dropdown menu showing the number 1.
- Start Time:** 2006/03/14 14:26:50
- End Time:** 2006/03/23 18:10:42
- Camera:** A dropdown menu showing the number 1.
- Start:** A text field containing "2006 Mar 14 Tue 14:26:50" with a calendar icon to its right.
- End:** A text field containing "2006 Mar 23 Thu 18:10:42" with a calendar icon to its right.
- At the bottom, there are two buttons: **Archive** and **Stop**.

In order to read the archived EDR MPEG Files (.arv), you would need to download viewer:

- I. Press **Download DVRViewer** button.

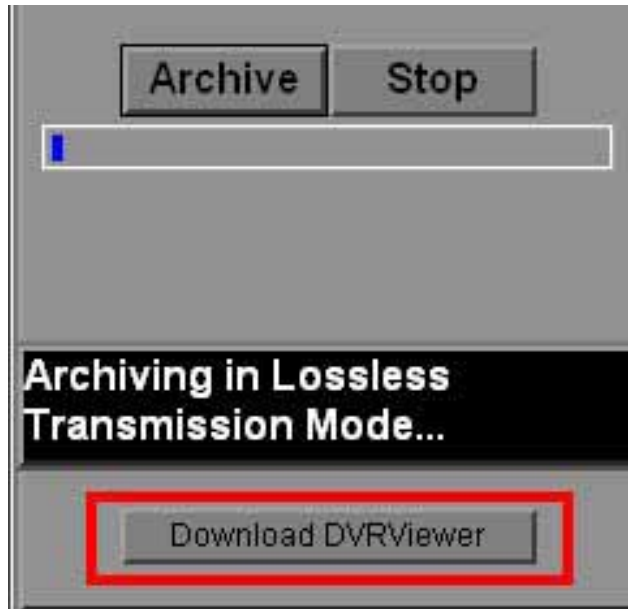

- II. Select **“Run”** or **“Save”** the file.

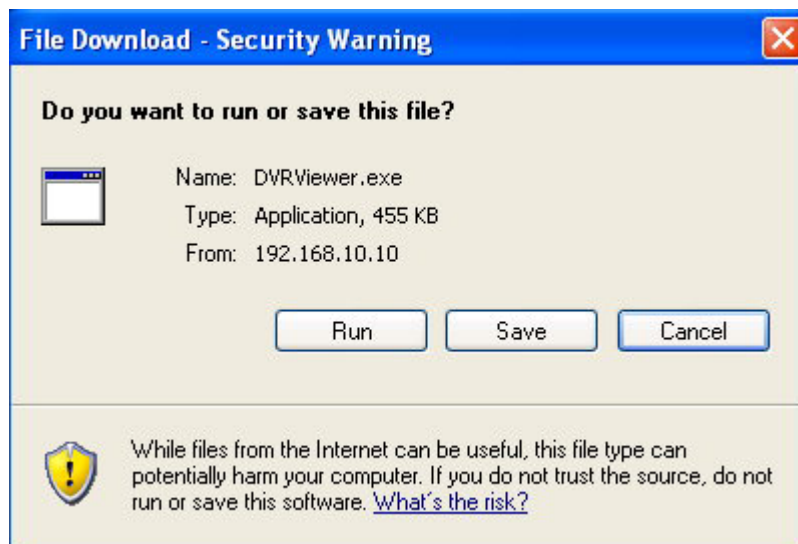



III. Open the DVRViewer.exe for loading the archived EDR MPEG Files (.arv)

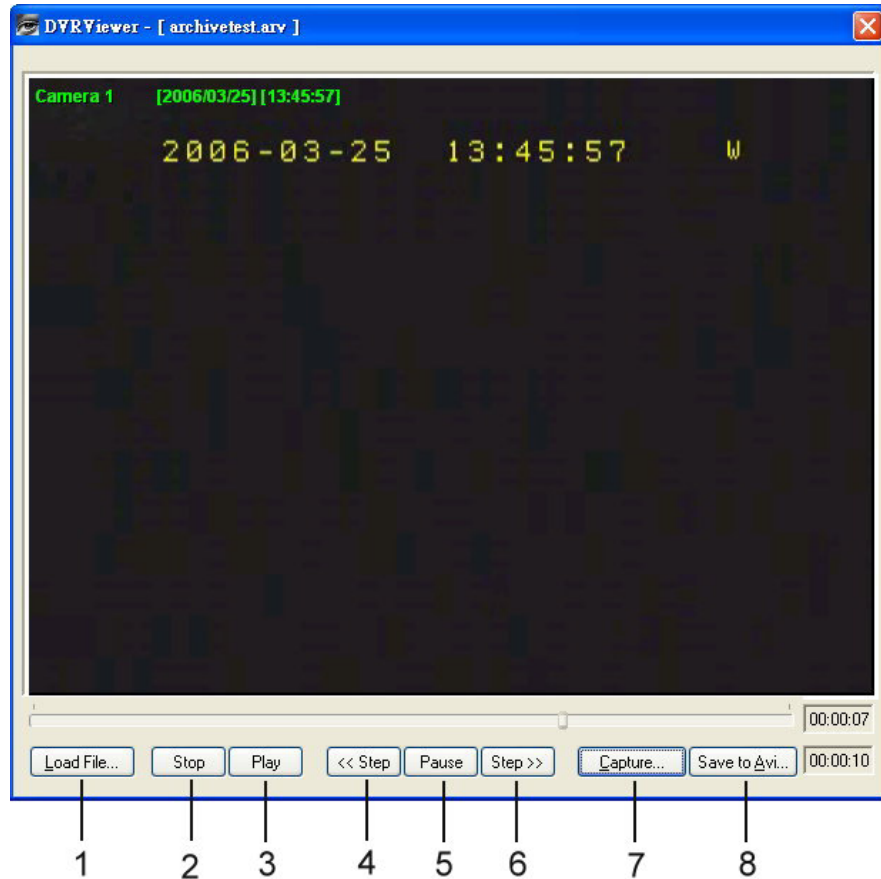

Detailed explanation of DVRViewer is as follows:

1. **Load File:** to load the archived EDR MPEG Files (.arv).
2. **Stop:** to stop playing “.arv” file.
3. **Play:** to play “.arv” file.
4. **<<Step:** step backward of the playing file.
5. **Pause:** to pause playing.
6. **Step>>:** step forward of the playing file.
7. **Capture:** to capture the playing image as “.jpg” file.
8. **Save to Avi:** to save the archived EDR MPEG File as “.AVI” file.

**Note:** If you are unable to play “AVI” file downloaded from “DVRViewer”, your PC is required to install “CODEC”, please go to the following URL: <http://www.divx.com/divx/play/download/index.php> for downloading DivXPlay.exe. This will enable you to play “AVI” file successfully.

## 15. Interface Specifications

RS232

This Digital Video Recorder may be controlled by a computer or a terminal via the standard D-SUB 9-pin RS-232 connector.

- D-SUB 9-pin connector specifications:

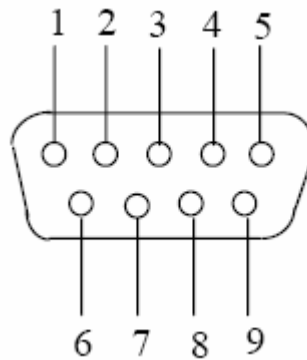

- The pin assignment of the 9-pin D-SUB connector

Digital Video Recorder			HOST	
PIN #	NAME		PIN #	NAME
1	NOT CONNECTED		1	NOT CONNECTED
2	TXD	→	2	RXD
3	RXD	←	3	TXD
4	NOT CONNECTED		4	NOT CONNECTED
5	GROUND	—	5	GROUND
6	NOT CONNECTED		6	NOT CONNECTED
7	NOT CONNECTED		7	NOT CONNECTED
8	NOT CONNECTED		8	NOT CONNECTED
9	NOT CONNECTED		9	NOT CONNECTED

## ***15.1 Transmission Setting***

There are 6 different speeds that can be used to transmit instruction or information through the RS232/RS485 port on the device, 1200 baud, 2400 baud, 4800 baud, 9600 baud, 19200 baud, and 3840 baud. The default setting from the factory is 9600 baud. Please refer to RS232/RS485 Setting Menu on page 32 for details.

## Appendix A: Remote Control

The remote controller (RC-200, Figure 1) is an accessory to enhance the handy operations of the DVR. You can perform all the settings and operations by the remote controller. The effective distance is up to 10 meters without any obstacle. The keypad functions are same as the front panel key button of the DVR.

There are some replacement keys for JOG and SHUTTLE, definitions are:

JOG ► : Same as turning the JOG clockwise.

JOG ◀ : Same as turning the JOG counter-clockwise.

SHUTTLE ►►

- 1: fast forward 2X or slow forward 1/2X.
- 2: fast forward 4X or slow forward 1/4X.
- 3: fast forward 8X or slow forward 1/8X.
- 4: fast forward 16X or slow forward 1/10X.
- 5: fast forward 32X or slow forward 1/16X.
- 6: fast forward 600X or slow forward 1/32X.

SHUTTLE ◀◀

- 1: fast rewind 2X or slow rewind 1/2X.
- 2: fast rewind 4X or slow rewind 1/4X.
- 3: fast rewind 8X or slow rewind 1/8X.
- 4: fast rewind 16X or slow rewind 1/10X.
- 5: fast rewind 32X or slow rewind 1/16X.
- 6: fast rewind 600X or slow rewind 1/32X.

Note: The channel keys #10~16 are not available.

Reserved only for 16 CH DVR.

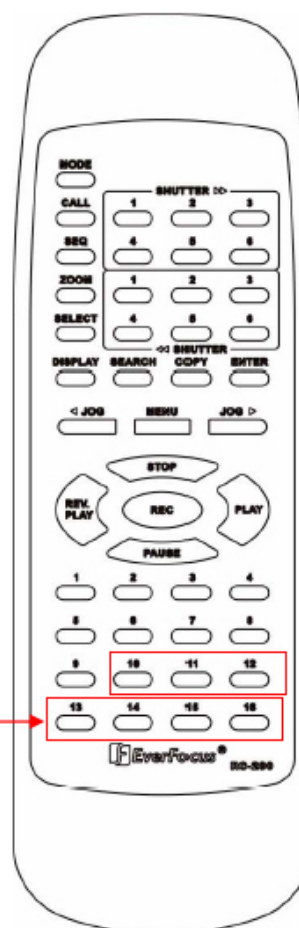

## Appendix B: Alarm Board Configuration

The alarm connector, Figure 1, is used to provide one sensor alarm input for each camera input. For easy operation, an alarm extension board, Figure 2, is provided to connect to the alarm connector.

Each alarm input requires two wires, one wire connects to the desired alarm input pin, the second wire connects to the ground. The alarm signal assignment is shown at the following.

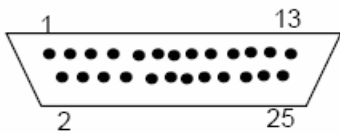

<Figure 1>  
D-SUB 25 pin female connector (DVR)

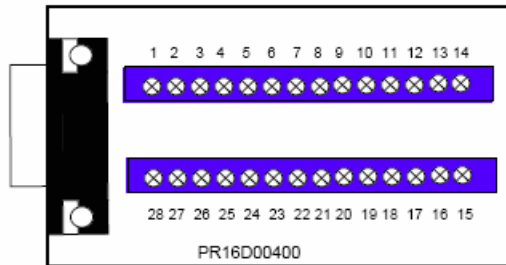

<Figure 2>  
PR16D00400 Alarm extension board (HOST).

DVR	
PIN #	NAME
1	GND
2	ALM 1
3	ALM 2
4	ALM 3
5	ALM 4
6	ALM 5
7	ALM 6
8	ALM 7
9	ALM 8
10	ALM 9
11	RESERVED
12	RESERVED
13	RESERVED
14	RESERVED
15	RESERVED
16	RESERVED
17	RESERVED
18	ALMRSTO
19	REC
20	GIN10
21	DISKFULL
22	GO1
23	ALM-N.C
24	ALM-N.O
25	ALM-COM

HOST	
PIN #	NAME
1	GND
2	ALM 1
3	ALM 2
4	ALM 3
5	ALM 4
6	ALM 5
7	ALM 6
8	GND
9	ALM 7
10	ALM 8
11	ALM 9
12	ALM10
13	ALM 11
14	ALM 12
15	ALM 13
16	ALM 14
17	ALM 15
18	ALM 16
19	ALMRST
20	REC-IN
21	GND
22	SPARE-IN
23	DISKFULL
24	SPARE-OUT
25	ALM-N.C
26	ALM-N.O
27	ALM-COM
28	GND

ALM10~ALM16 are reserved only for 16 CH DVR.

## Appendix C: RJ45 (RS485) Pin Assignment

There are two RJ-45 (RS-485) connectors on the back panel of the DVR. Please refer the following pin assignment for application.

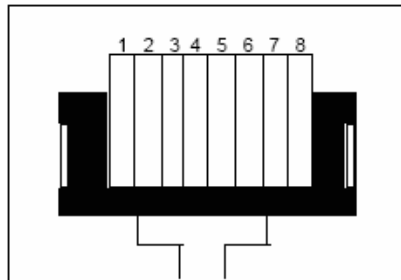

PIN #	NAME
1	GND
2	NC
3	RX
4	NC
5	NC
6	TX
7	NC
8	NC

## Appendix D: Time Lapse Mode Recording Table

**Resolution: 720 x 480**

**System Storage: 250 GB**

		video source	
		Simple:	Complex:
Average size per image	LOWER:	8.04KB	12.33KB
	LOW:	8.42KB	13.7KB
	BASIC:	10.15KB	16.72KB
	STANDARD:	11.86KB	19.56KB
	HIGH:	14.72KB	24.63KB
	SUPERIOR:	18.60KB	30.05KB

### Terms of Use

The HDD size required in your DVR may vary from this calculated test result under some conditions. Total storage capacity may vary depending on complexity of video scenes, DVR specifications and features used on the actual installation sites. Test results and information obtained from these tables are furnished for informational use only. It is user's responsibility to test and allocate appropriate HDD size for his/her DVR systems.

*For 1640 model*

NTSC		Unit: Hour											
Recording Speed (IPS)	PICTURE QUALITY (KB)												
	LOWER		LOW		BASIC		STANDARD		HIGH		SUPERIOR		
	simple	complex	simple	complex	simple	complex	simple	complex	simple	complex	simple	complex	
	8.04	12.33	8.42	13.7	10.15	16.72	11.86	19.56	14.72	24.63	18.6	30.05	
120	71.978	46.93	68.73	42.24	57.02	34.61	48.79	29.59	39.31	23.50	31.11	19.26	
96	89.973	58.67	85.91	52.80	71.27	43.26	60.99	36.98	49.14	29.37	38.89	24.07	
80	107.97	70.40	103.09	63.36	85.52	51.92	73.19	44.38	58.97	35.24	46.67	28.89	
64	134.96	88.00	128.87	79.20	106.90	64.90	91.49	55.47	73.71	44.05	58.34	36.11	
48	179.95	117.34	171.82	105.60	142.54	86.53	121.99	73.97	98.29	58.74	77.78	48.15	
32	269.92	176.00	257.74	158.40	213.81	129.79	182.98	110.95	147.43	88.11	116.67	72.22	
16	539.84	352.01	515.47	316.81	427.61	259.59	365.96	221.90	294.86	176.22	233.35	144.44	

PAL		Unit: Hour											
Recording Speed (IPS)	PICTURE QUALITY (KB)												
	LOWER		LOW		BASIC		STANDARD		HIGH		SUPERIOR		
	simple	complex	simple	complex	simple	complex	simple	complex	simple	complex	simple	complex	
	8.04	12.33	8.42	13.7	10.15	16.72	11.86	19.56	14.72	24.63	18.6	30.05	
100	86.374	56.32	82.48	50.69	68.42	41.53	58.55	35.50	47.18	28.20	37.34	23.11	
80	107.97	70.40	103.09	63.36	85.52	51.92	73.19	44.38	58.97	35.24	46.67	28.89	
64	134.96	88.00	128.87	79.20	106.90	64.90	91.49	55.47	73.71	44.05	58.34	36.11	
48	179.95	117.34	171.82	105.60	142.54	86.53	121.99	73.97	98.29	58.74	77.78	48.15	
32	269.92	176.00	257.74	158.40	213.81	129.79	182.98	110.95	147.43	88.11	116.67	72.22	
16	539.84	352.01	515.47	316.81	427.61	259.59	365.96	221.90	294.86	176.22	233.35	144.44	



***For 1620/920 model***

NTSC		Unit: Hour											
Recording Speed (IPS)	PICTURE QUALITY (KB)												
	LOWER		LOW		BASIC		STANDARD		HIGH		SUPERIOR		
	simple	complex	simple	complex	simple	complex	simple	complex	simple	complex	simple	complex	
	8.04	12.33	8.42	13.7	10.15	16.72	11.86	19.56	14.72	24.63	18.6	30.05	
60	143.96	93.87	137.46	84.48	114.03	69.22	97.59	59.17	78.63	46.99	62.23	38.52	
48	179.95	117.34	171.82	105.60	142.54	86.53	121.99	73.97	98.29	58.74	77.78	48.15	
40	215.93	140.80	206.19	126.72	171.05	103.83	146.38	88.76	117.94	70.49	93.34	57.77	
32	269.92	176.00	257.74	158.40	213.81	129.79	182.98	110.95	147.43	88.11	116.67	72.22	
24	359.89	234.67	343.65	211.21	285.08	173.06	243.97	147.93	196.57	117.48	155.57	96.29	
16	539.84	352.01	515.47	316.81	427.61	259.59	365.96	221.90	294.86	176.22	233.35	144.44	

PAL		Unit: Hour											
Recording Speed (IPS)	PICTURE QUALITY (KB)												
	LOWER		LOW		BASIC		STANDARD		HIGH		SUPERIOR		
	simple	complex	simple	complex	simple	complex	simple	complex	simple	complex	simple	complex	
	8.04	12.33	8.42	13.7	10.15	16.72	11.86	19.56	14.72	24.63	18.6	30.05	
50	172.75	112.64	164.95	101.38	136.84	83.07	117.11	71.01	94.35	56.39	74.67	46.22	
40	215.93	140.80	206.19	126.72	171.05	103.83	146.38	88.76	117.94	70.49	93.34	57.77	
32	269.92	176.00	257.74	158.40	213.81	129.79	182.98	110.95	147.43	88.11	116.67	72.22	
24	359.89	234.67	343.65	211.21	285.08	173.06	243.97	147.93	196.57	117.48	155.57	96.29	
16	539.84	352.01	515.47	316.81	427.61	259.59	365.96	221.90	294.86	176.22	233.35	144.44	

## Troubleshooting

If you have difficulty operating your system, run through the following checklist to see if you can solve the problem.

- **The DVR will not go into record mode?**
  - Make sure the HDD is locked in with the keys. Also check to make sure the hard drives are set to Master. A diagram located on the Hard Drive Label will show you how to set the drive to master.
- **The DVR displays no picture?**
  - First question you should ask yourself is the equipment wired properly. Please see your installation manual for help.
  - The second question to ask yourself, do all the wires used work properly.
  - The next step is to verify the recorder is getting the correct amount of power.
- **There is no display coming from one of the channels on the DVR?**
  - The first step is to verify is the problem coming from the recorder or the camera.
  - Simply take a working camera and plug it into the port that seems to not be working. If you see a picture this means the problem is coming from the camera.
- **I cannot connect to the recorder via the internet?**
  1. The first thing to check is does your internet provider block any ports.
  2. Are you using the IP address from the Internet Service provider?
  3. If you are using a router are the ports in your router opened?  
(NOTE: Please be sure that HTTP port, Control port, Data port are open. Please refer to “Network Setup Menu” section for port settings. For example, HTTP port: 00080, Control port: 01600, Data port: 37260, the last digit +1 which is 37261, +2 which is 37262 and +3 which is 37263.)

4. If you are using Windows XP please update the Java Virtual Machine. This can be done by going to <http://java.sun.com> and downloading the file called JavaVM.
- **If you have a Dynamic IP address from your Internet Service Provider.**
    - Dynamic IP addresses can cause conflicts when trying to connect to DVR(s) on a high speed internet connection. With new router technology (DDNS), it allows you to overcome this problem. DDNS lets you assign a fixed host and domain name to a dynamic Internet IP address. It is useful when you are hosting your own DVR, website, FTP server, or other server behind the Router. Before using this feature, you need to sign up for DDNS service at [www.dyndns.org](http://www.dyndns.org) or [www.tzo.com](http://www.tzo.com). (Preferred routers: Linksys BEFSR41 V3 or DLINK DI624 or any router that offers DDNS.



*Security Products*

**Head Office New South Wales:**

Unit 4, 167 Prospect Highway,  
Seven Hills NSW 2147  
TEL : 61-2-8825-9222  
FAX: 61-2-9674-2520  
Email: sales@ness.com.au

**Victoria Branch:**

24 Terracotta Drive,  
Blackburn VIC 3130  
TEL : 61-3-9878 1022  
**FAX: 61-3-9878 4257**  
Email: nessmelb@ness.com.au

**Queensland Branch:**

36 Devlan Street  
Mansfield QLD 4122  
TEL: 61-7-3343 7744  
FAX: 61-7-3849 4883  
Email: nessbris@oznetcom.com.au

**Western Australia Branch:**

Unit 1, 567 Newcastle Street,  
Perth WA 6000  
TEL: 61-8-9328 2511  
FAX: 61-8-9227 7073  
Email: nessper@iinet.net.au

**Hong Kong Office:**

Unit E, 6F China Insurance Building  
48 Cameron Rd Tsimshatsui  
Kowloon Hong Kong  
TEL : 852-2721-8097  
FAX: 852-2721-7465

**New Zealand Distributor:**

National Fire & Security (N.F.S.)  
Unit 5, 517 Mt Wellington Highway  
Mt Wellington Auckland  
TEL: 64-9-573 0401  
FAX: 64-9-573 0402  
Email: office@nfs.co.nz

**South Australian Distributor**

Aquavia Controls  
13 Weaver Street  
Edwardstown S.A. 5039  
TEL: 61-8-8277 7255  
FAX: 61-8-8276 3028  
Email: aquavia@cobweb.com.au

P/N: MR92G0040A